

mounting direction

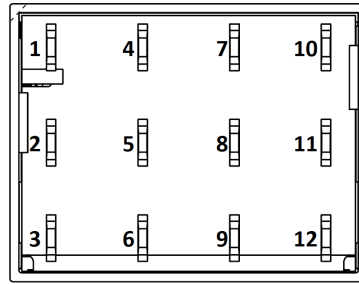

view of plug

DESCRIPTION

A world first - the patented MicroPlex® is the smallest CAN controller with the highest integration density. The 3 CAN LIN Gateway is equipped with 3 CAN transceivers and optionally LIN.

TECHNICAL DATA

Housing	PA66GF30
Connector	2.8 mm tab
Weight	17 g
Temperature range (ISO 16750-4 compliant)	-40...+85°C
Environmental protection	IP67 in combination with fuse box, IP68 with waterproof socket
Current consumption	52 mA @ 12 V 30 mA @ 24 V
Over-current protection	1 A
Total inputs and outputs	2 inputs (1 of them multi purpose)
Inputs	1 x Analog / digital 1 x Configurable as: Analog with range selection / digital / PWM / sensor input / current input
Operating voltage	8...32 V
Overvoltage protection	≥ 33 V
Quiescent current	< 70 µA @ 24 V
Reverse polarity protection	Yes
CAN Interfaces	3 x CAN interface 2.0 A/B, ISO 11898-2 compliant, CAN-FD capable
LIN Interface	1 x optional

REGULATORY APPROVALS AND TESTING

E1 Label	06 10205
Electrical tests	Acc. to ISO 16750: Operating voltage range Short circuit protection Reverse polarity Storage test Tmax and Tmin Operational test Tmax and Tmin Temperature step test Starting Profile Superimposed alternating voltage Slow decrease and increase of supply voltage Momentary drop in supply voltage Reset behavior at voltage drop Overvoltage at 65°C Ground offset Single line interruption multiple line interruption Acc. to ISO 7637 - 2:2004: Puls 1, 2a, 2b, 3a, 3b ESD up to ± 8 kV to connector pins, all others up to ± 15 kV acc. to ISO 10605:2008
Patent Number	3384603

SOFTWARE/PROGRAMMING

Programming system

MRS APPLICS STUDIO

The Applics Studio is the new development and tool platform for our assemblies. Program your MRS controls quickly and easily with our stand-alone software. The focus is on your application.



INPUT FEATURES - SUMMARY

Pin 2 (Multifunctional input)	Programmable as Analog- or Digital input, Frequency input, Current input or Sensor input	Resolution	12 Bit
Voltage input 0...16.5 V (see A) ¹	Input resistance	29 kΩ	
	Input frequency	$f_g^2 = 180 \text{ Hz}$	
	Deviation	$\leq 3 \%$	
Voltage input 0...34.5 V (see B)	Input resistance	26 kΩ	
	Input frequency	$f_g^2 = 390 \text{ Hz}$	
	Deviation	$\leq 3 \%$	
Digital input ³	Input resistance	29 kΩ	
	Switch-on threshold	8.9 V $\pm 0.3 \text{ V}$	
	Switch-off threshold	6.9 V $\pm 0.3 \text{ V}$	
Frequency input 0...23 kHz (see C) ³	Input resistance	36 kΩ	
	Switch-on threshold	2.2 V $\pm 0.3 \text{ V}$ (up to 16 kHz)	
	Switch-off threshold	1.5 V $\pm 0.3 \text{ V}$ (up to 13 kHz)	
	Min. pulse width	4 μs	
	Meas. range PWM	20...98 % (up to 1 kHz)	
	Deviation Frequency measurement	$\leq 3 \%$	
Current input 0...25 mA (see D) ⁴	Input resistance	330 Ω to GND	
	Conversion factor	1 mA ≈ 83.2 digits	
	Deviation	$\leq 3 \%$	
Sensor input (see E)	Input resistance	1 kΩ to Power Supply	

Pin 12	Programmable as Analog- or Digital input	Resolution	12 Bit
Voltage input 0...34.5 V	Input resistance	52 kΩ	
	Input frequency	$f_g^2 = 390 \text{ Hz}$	
	Deviation	$\leq 3 \%$	
Digital input	Input resistance	52 kΩ	
	Switch-on threshold	18.6 V $\pm 0.3 \text{ V}$	
	Switch-off threshold	14.5 V $\pm 0.3 \text{ V}$	

¹Standard configuration
²Cut-off frequency (-3 dB), measured with square signal 0...10 V_{Peak}
³When using the standard configuration, see¹
⁴When using the pull down no voltage higher than 8.5 V may be present, otherwise the pulldown is automatically deactivated for safety reasons

PIN ASSIGNMENT POWER SUPPLY AND INTERFACES

Pin	Description	Pin	Description
1	Ground	7	CAN2 - L
3	Operating voltage / contact 30	8	CAN2 - H
4	CAN0 - L	9	LIN
5	CAN0 - H	10	CAN1 - L
6	Ignition / contact 15	11	CAN1 - H

PIN ASSIGNMENT INPUTS AND OUTPUTS

Pin	Signal	Description	Pin	Signal	Description
2	AI_1	Analog Input 1	12	AI_2	Analog Input 2 or
	DI_AI_1	Digital Input 1		DI_AI_2	Digital Input 2
	DO_PU_1	activate 1 kΩ up to VDD			
	DO_RS_1	activate measurement range up to 34.5 V			
	DO_CUR_1	activate 330 Ω Pull down			
6	AI_KL15	Analog Input KL15 or			
	DI_AI_KL15	Digital Input KL15			

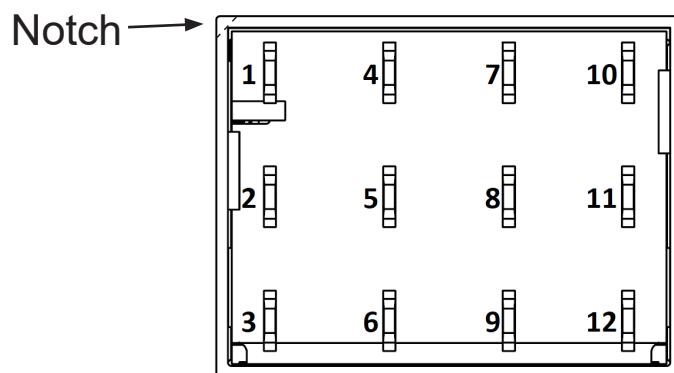

Pin assignment - bottom view

When connecting the module, it is important to pay attention to the correct terminal assignment and direction (see notch) of the module. Improper connection (such as twisting or shifting) can cause unexpected behavior and / or dangerous situations!

PIN FEATURE MAP

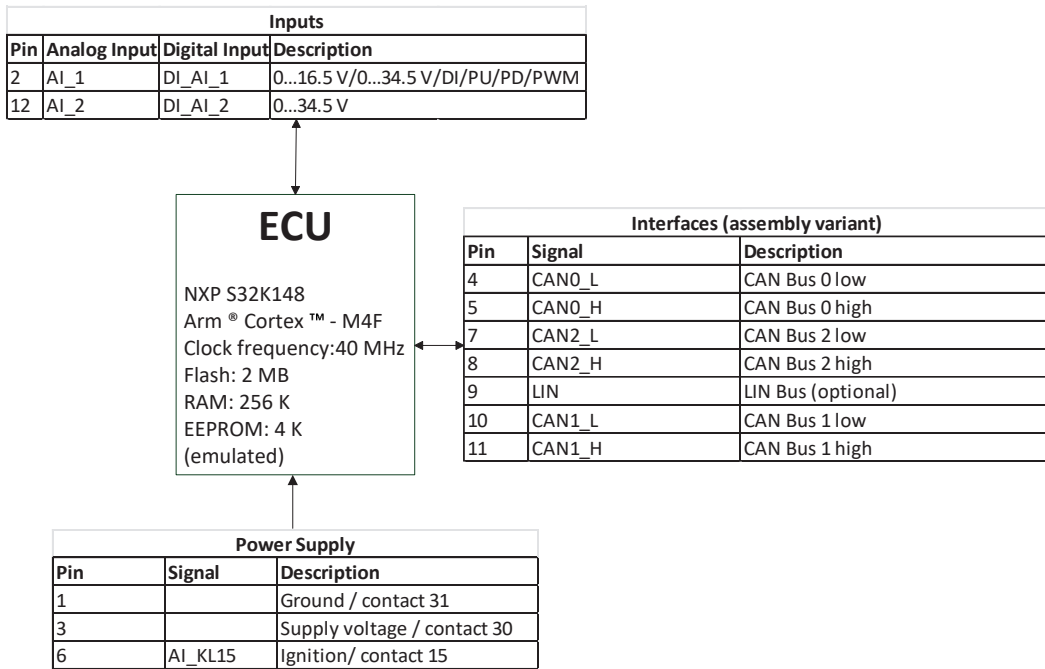

BLOCK FUNCTION DIAGRAM

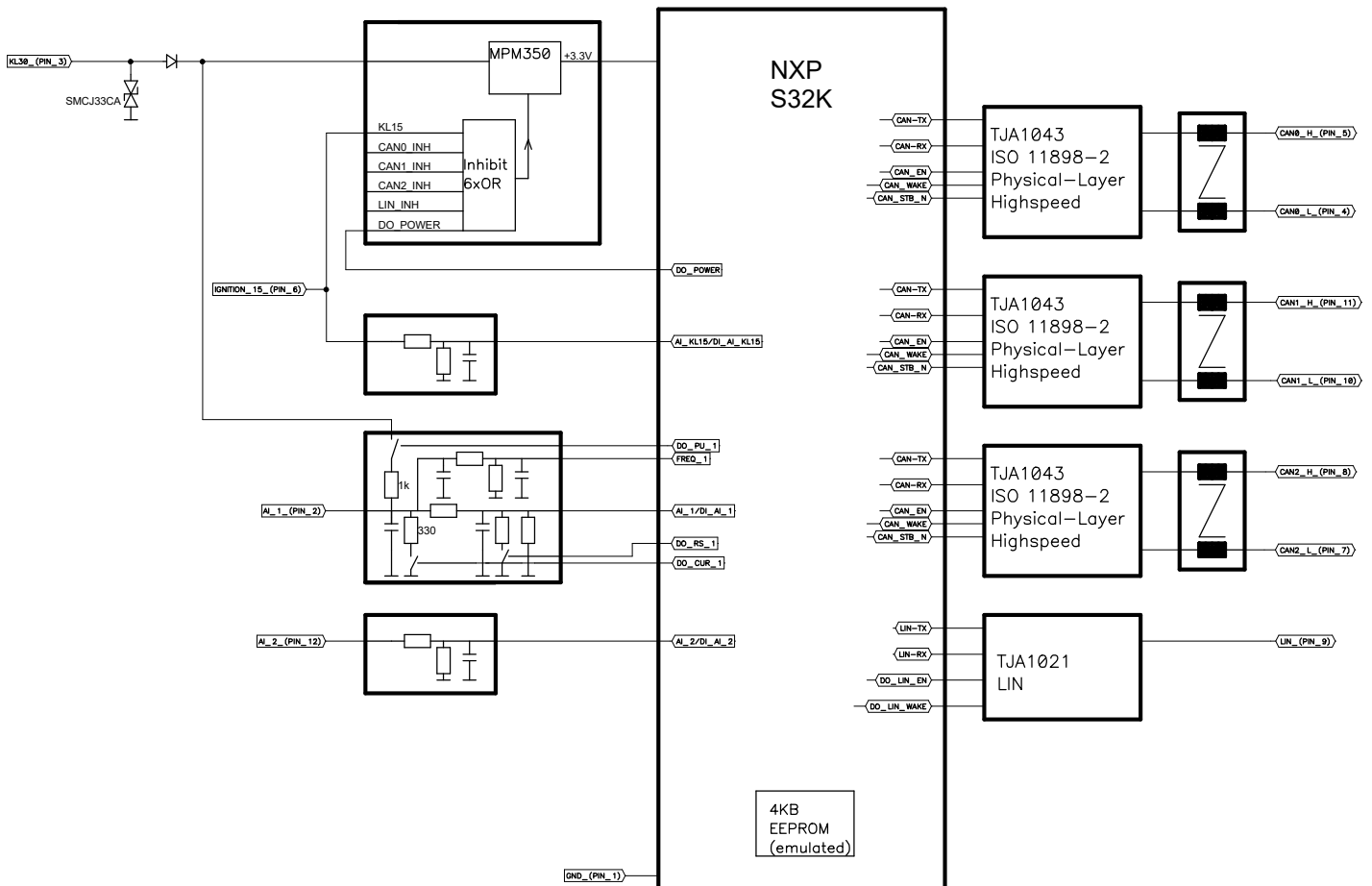

TECHNICAL DRAWING IN MM

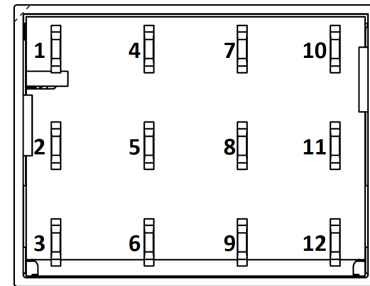
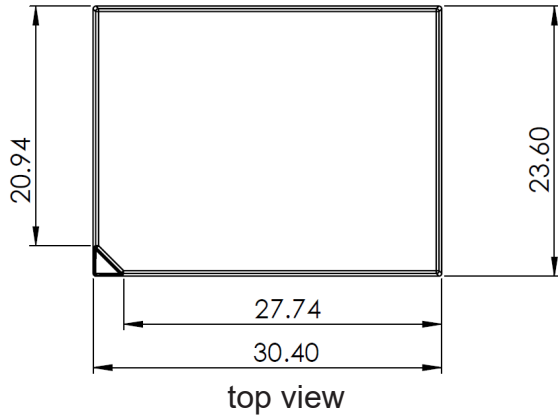

bottom view

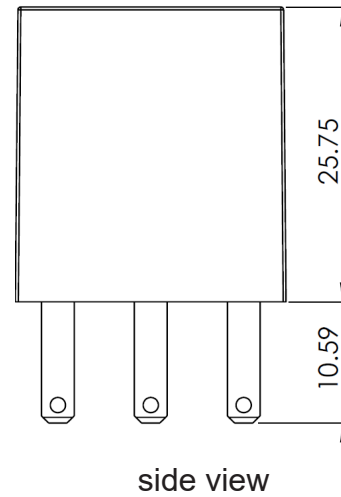
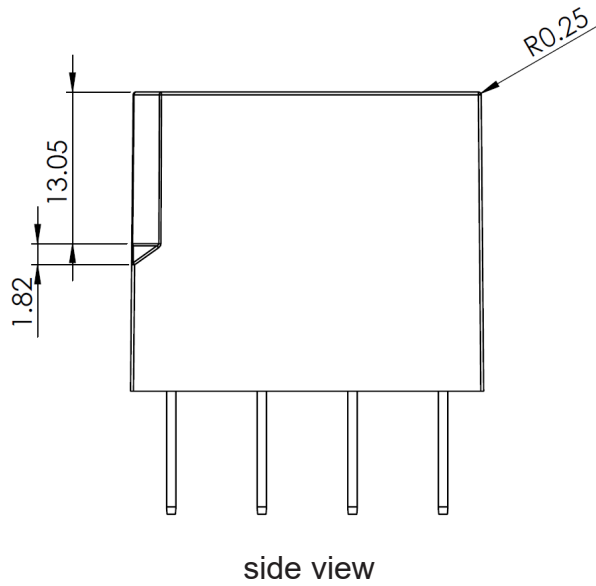



ASSEMBLY OPTIONS AND ORDERING INFORMATION

	Pin numbering of the inputs					CAN Bus	LIN	Wake-Up
	A Voltage 0...16.5 V	B Voltage 0...34.5 V	C Frequency input 0...23 kHz	D Current input 0...25 mA	E Sensor input 1 kΩ to Supply	High-Speed		
1.141.300.0001	2	2, 12	2	2	2	4/5 7/8 10/11	9 (Master, 1 kΩ Pull up to VDD30)	CAN0, CAN1, CAN2, DO_POWER, LIN KL15
1.141.300.0221	2	2, 12	2	2	2	4/5 7/8 10/11		CAN0, CAN1, CAN2, DO_POWER, KL15

ACCESSORIES

Description	Order number
Applics Studio Bundle without PCAN	1.100.200.01
MicroPlex socket (Fuseholder)	1.017.055.0000
Programming cable set MicroPlex 7X/7L/7H	302365
Crimp contact set with wire seals	1.017.055.1003
PCAN-USB Interface	105358
Socket Microplex waterproof	1.017.055.1000



Image similar

MANUFACTURER

MRS Electronic, Inc.
 6680 Poe Avenue Suite 100
 Dayton OH, 45414
 USA

NOTES ON WIRING AND CABLE ROUTING

CAN bus/LIN bus communication is the main communication between the control unit and the vehicle. Therefore, connect the CAN bus with special care and check the correct communication with the vehicle to avoid undesired behavior.

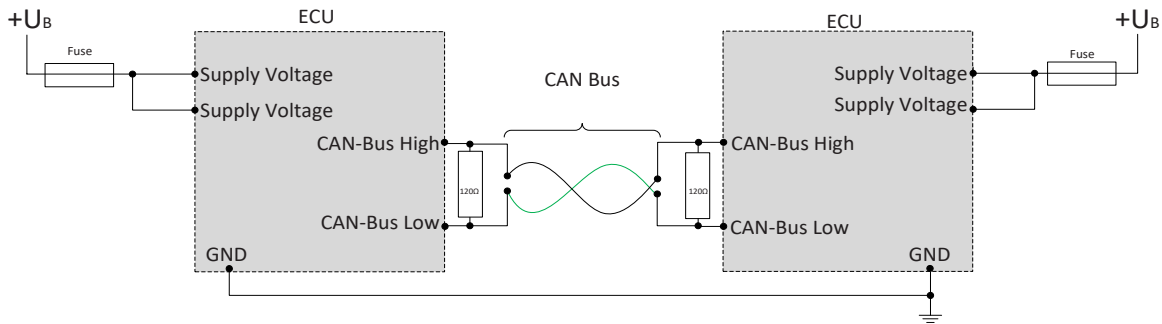

When using the input with pull-down resistance (using DO_CUR_1), you must not connect a greater voltage than 8.5 V to the input.

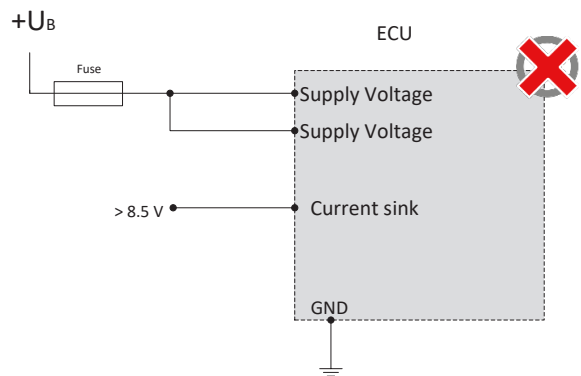
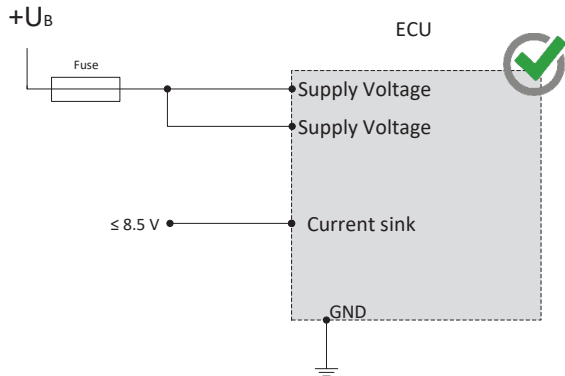

The control unit must be protected against overload

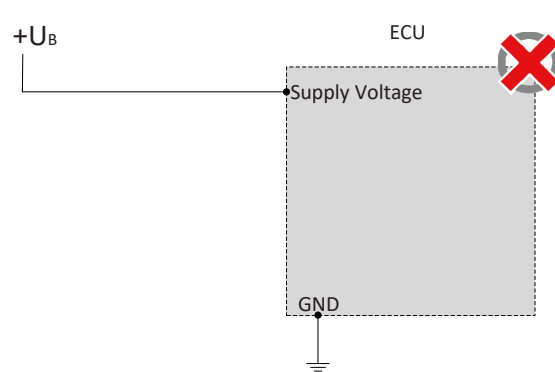
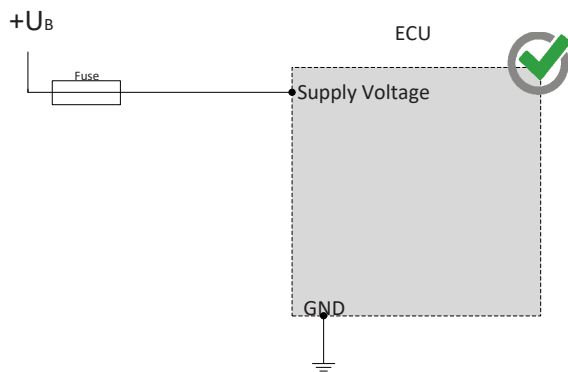

SAFETY AND INSTALLATION INFORMATION

It is essential to read the instructions in full thoroughly before working with the device.

Please note and comply with the instructions in the operating instructions and the information in the device data sheet, see www.mrs-electronic.de

Staff qualification: Only staff with the appropriate qualifications may work on this device or in its proximity.

SAFETY



WARNING! Danger as a result of a malfunction of the entire system.

Unforeseen reactions or malfunctions of the entire system may jeopardise the safety of people or the machine.

- Ensure that the device is equipped with the correct software and that the wiring and settings on the hardware are appropriate.



WARNING! Danger as a result of unprotected moving components.

Unforeseen dangers may occur from the entire system when putting the device into operation and maintaining it.

- Switch the entire system off before carrying out any work and prevent it from unintentionally switching back on.
- Before putting the device into operation, ensure that the entire system and parts of the system are safe.
- The device should never be connected or separated under load or voltage.



CAUTION! Risk of burns from the housing.

The temperature of the device housing may be elevated.

- Do not touch the housing and let all system components cool before working on the system.

PROPER USE

The device is used to control or switch one or more electrical systems or sub-systems in motor vehicles and machines and may only be used for this purpose. The device may only be used in an industrial setting.



WARNING! Danger caused by incorrect use.

The device is only intended for use in motor vehicles and machines.

- Use in safety-related system parts for personal protection is not permitted.
- Do not use the device in areas where there is a risk of explosion.

Correct use:

- operating the device within the operating areas specified and approved in the associated data sheet.
- strict compliance with these instructions and no other actions which may jeopardise the safety of individuals or the functionality of the device.

Obligations of the manufacturer of entire systems

It is necessary to ensure that only functional devices are used. If devices fail or malfunction, they must be replaced immediately.

System developments, installation and the putting into operation of electrical systems may only be carried out by trained and experienced staff who are sufficiently familiar with the handling of the components used and the entire system.

It is necessary to ensure that the wiring and programming of the device does not lead to safety-related malfunctions of the entire system in the event of a failure or a malfunction. System behaviour of this type can lead to a danger to life or high levels of material damage.

The manufacturer of the entire system is responsible for the correct connection of the entire periphery (e.g. cable cross sections, correct selection/connection of sensors/actuators).

Opening the device, making changes to the device and carrying out repairs are all prohibited. Changes or repairs made to the cabling can lead to dangerous malfunctions. Repairs may only be carried out by MRS.

Installation

The installation location must be selected so the device is exposed to as low a mechanical and thermal load as possible. The device may not be exposed to any chemical loads.

Install the device in such a manner that the plugs point downwards. This means condensation can flow off the device. Single seals on the cables/leads must be used to ensure that no water gets into the device.

Putting into operation

The device may only be put into operation by qualified staff. This may only occur when the status of the entire system corresponds to the applicable guidelines and regulations.

FAULT CORRECTION AND MAINTENANCE



NOTE The device is maintenance-free and may not be opened.

- If the device has damage to the housing, latches, seals or flat plugs, it must be taken out of operation.

Fault correction and cleaning work may only be carried out with the power turned off. Remove the device to correct faults and to clean it.

Check the integrity of the housing and all flat plugs, connections and pins for mechanical damage, damage caused by overheating, insulation damage and corrosion. In the event of faulty switching, check the software, switches and settings.

Do not clean the device with high pressure cleaners or steam jets. Do not use aggressive solvents or abrasive substances.