

mounting direction

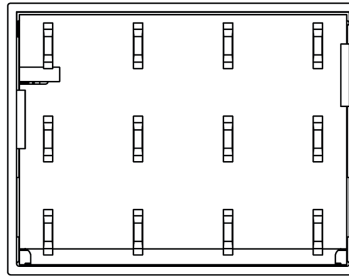

view of plug

DESCRIPTION

A world first - the patented MicroPlex® is the smallest CAN controller with the highest integration density. On the footprint of two Micro 280 relays and a drag-and-drop configuration tool, CAN bus-capable power distribution systems can easily be built.

TECHNICAL DATA

Housing	PA66GF30
Connector	2.8 mm tab
Weight	50 g
Temperature range (ISO 16750-4 complaint)	- 40 °C to +85 °C
Environmental protection	IP 67 in combination with fuse box
Current consumption	26 mA at 12 V and 24 V
Over-current protection	1 A + load
Total inputs and outputs	7 low-side outputs
Inputs	<b>Configurable as:</b> N.A.
Outputs	<b>Configurable as:</b> Digital output PWM output
Operating voltage	9-32 V
Starting voltage	≥ 9 V
Overvoltage protection	≥ 33 V
Undervoltage cut-off	≤ 9 V
Quiescent current	170 µA @ 12 V, 230 µA @ 24 V
Reverse polarity protection	Yes
CAN Interfaces	CAN interface 2.0 A/B, ISO 11898-5 complaint

REGULATORY APPROVALS AND TESTING

E1 Label	05 8489
Electrical tests	Acc. to ISO 16750: Short circuit protection Reverse polarity Storage test Tmax and Tmin Operational Tmax and Tmin
	Acc. to ISO 7637 - 2:2004: Puls 1, 2a, 2b, 3a, 3b, 4
Patent number	3384603

SOFTWARE/PROGRAMMING

Programming System	
<b>MRS Developers Studio</b>	
	MRS Developers Studio with built-in functional library, similar programming with FUP. Custom software blocks can be integrated into "C-code". Program memory is sufficient to about 300 basic logic components.



OUTPUT FEATURES - SUMMARY

Pin 2, 8, 9, 10, 11, 12			Pin 7		
Digital, grounding (Low-Side; see <a href="#">A</a> )	Switching voltage Switching current	≤ 32 V depending on the total load, see table below	Digital, grounding (Low-Side; see <a href="#">A</a> )	Switching voltage Switching current	≤ 32 V depending on the total load, see table below
PWM-output (see <a href="#">B</a> )	Output frequency	depending on the total load, see table below 2% full scale	Short-circuit strength against GND and US	The individual outputs are switched off by output drivers	
Short-circuit strength against GND and US		The individual outputs are switched off by output drivers			

PERFORMANCE TESTS AT T<sub>MAX</sub>

Test without PWM	Tested Channel	Load	Duration	Test with PWM	Tested Channel	PWM / DC	Load	Duration
1	All channels	0,6 A for each output (Σ 4.2 A)	Permanent	1	DO_OUTPUT_1 DO_OUTPUT_2 DO_OUTPUT_5 DO_OUTPUT_6	500 Hz 50 %	0.6 A for each output (Σ 2.4 A)	Permanent
2	Channel DO_OUTPUT_1 to DO_OUTPUT_4	0.7A for each output (Σ 2.8 A)	Permanent	2	DO_OUTPUT_1 DO_OUTPUT_2 DO_OUTPUT_5 DO_OUTPUT_6	1000 Hz 50 %	0.5 A for each output (Σ 2 A)	Permanent
3	DO_OUTPUT_1 DO_OUTPUT_5	1.3 A (Σ 2.6 A)	30 minutes					

PIN ASSIGNMENT POWER SUPPLY AND INTERFACES

Pin	Description	Pin	Description
1	Ground	6	Battery/ignition contact KL 15
3	Operating voltage		

PIN ASSIGNMENT INPUTS AND OUTPUTS

Pin	Signal	Description	Pin	Signal	Description
2	DO_OUTPUT_6 PWM_OUTPUT_6	Digital output OUTPUT_6 with PWM-possibility	9	DO_OUTPUT_4 PWM_OUTPUT_4	Digital output OUTPUT_4 with PWM-possibility
7	DO_OUTPUT_7	Digital output OUTPUT_7	10	DO_OUTPUT_3 PWM_OUTPUT_3	Digital output OUTPUT_3 with PWM-possibility
8	DO_OUTPUT_5 PWM_OUTPUT_5	Digital output OUTPUT_6 with PWM-possibility	11	DO_OUTPUT_2 PWM_OUTPUT_2	Digital output OUTPUT_2 with PWM-possibility
			12	DO_OUTPUT_1 PWM_OUTPUT_1	Digital output OUTPUT_1 with PWM-possibility

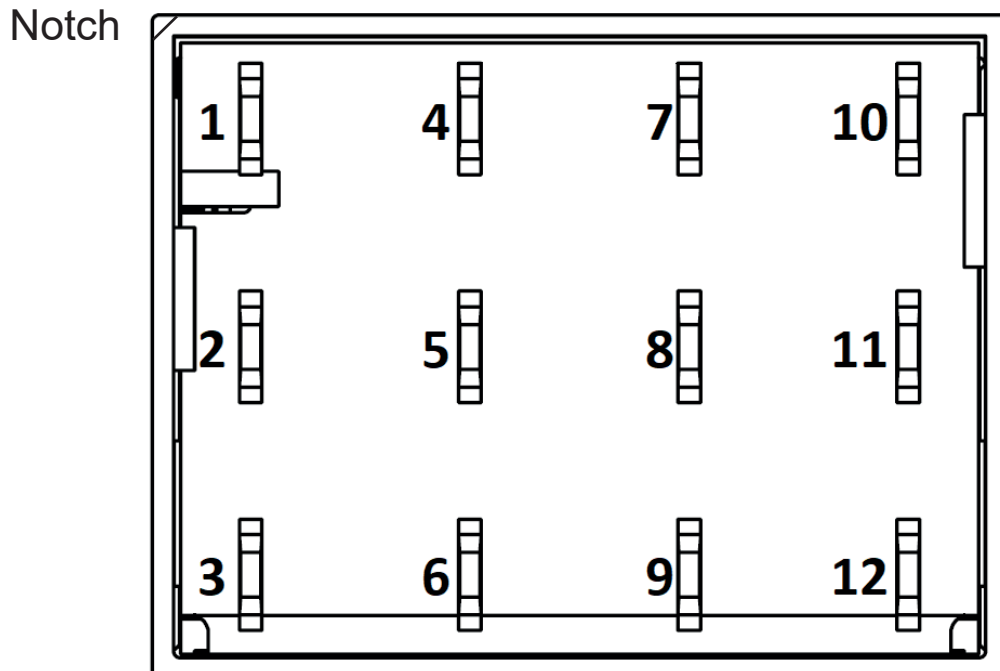

Pin assignment - bottom view

When connecting the module, it is important to pay attention to the correct terminal assignment and direction (see notch) of the module. Improper connection (such as twisting or shifting) can cause unexpected behavior and / or dangerous situations!

PIN - FEATURE MAP

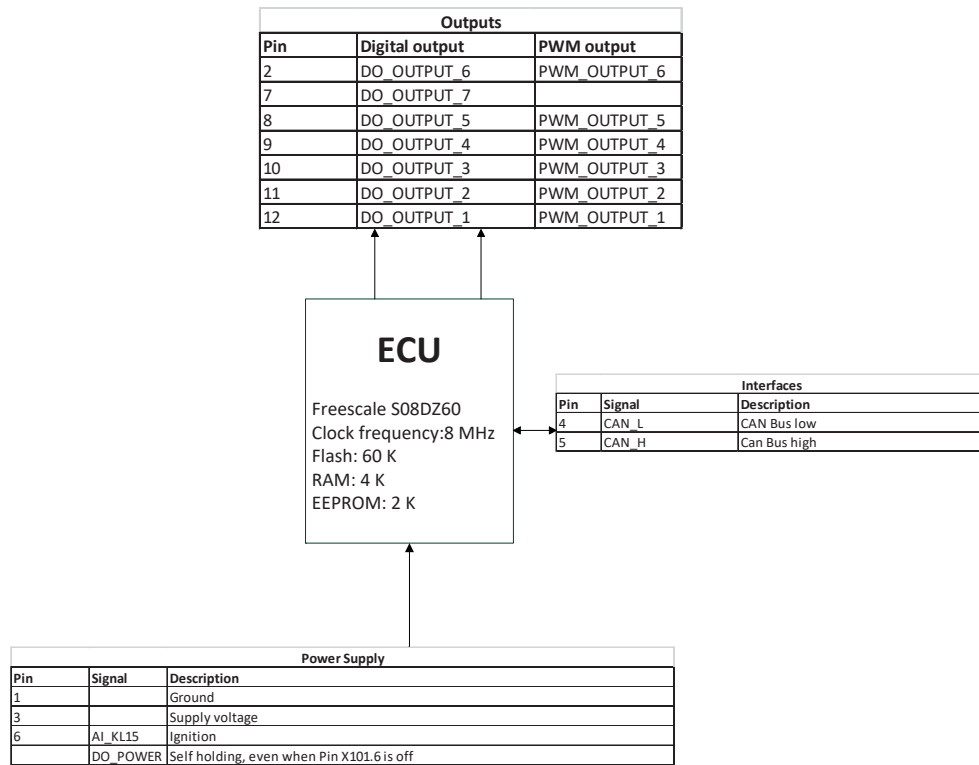

BLOCK FUNCTION DIAGRAM

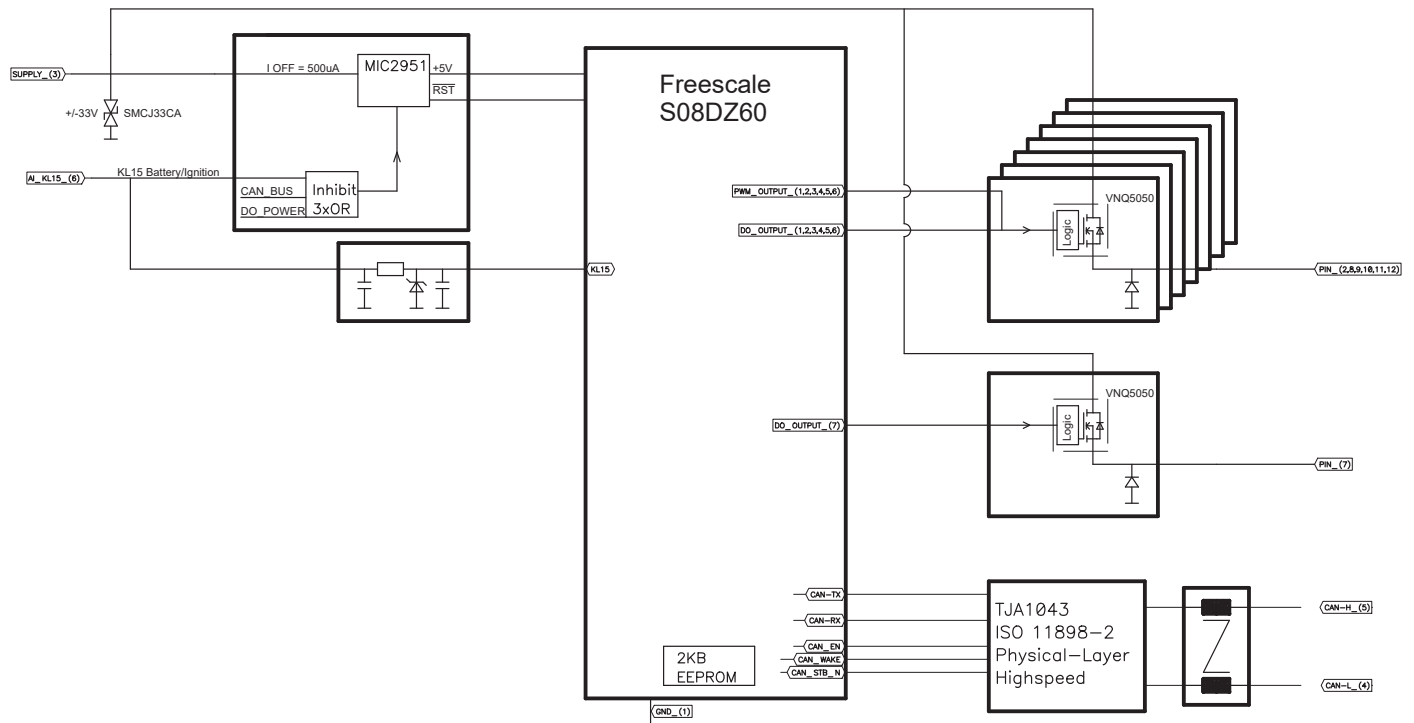

TECHNICAL DRAWING IN MM

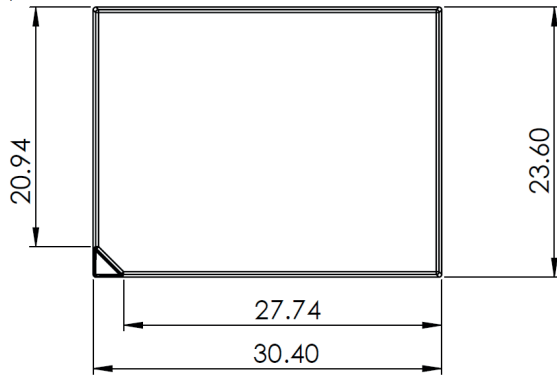

aerial view

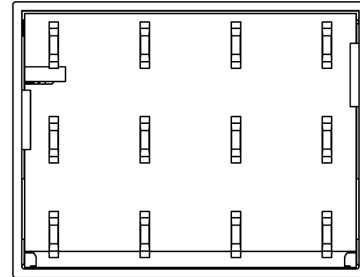

bottom view

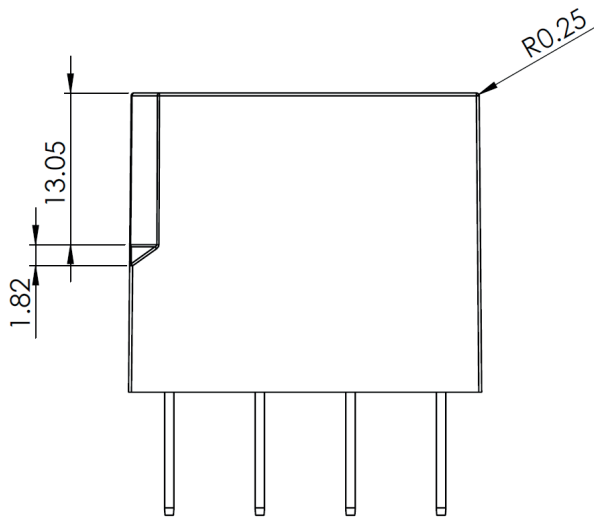

side view

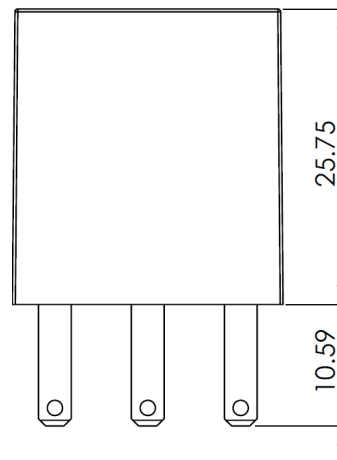

side view



ASSEMBLY OPTIONS AND ORDER INFORMATION

	Outputs		CAN bus
	A Digital output	B PWM-Output	High-Speed
<b>1.134.300.00</b>	2 7 8 9 10 11 12	2 8 9 10 11 12	4 5

ACCESSORIES

Description	Order number
Programming Tool MRS Developers Studio	1.100.100.09
MicroPlex Socket (Fuseholder)	301302
Wiring Harness for MicroPlex with Fuseholder	301301
Connector package MicroPlex	301288
PCAN-USB Interface	105358

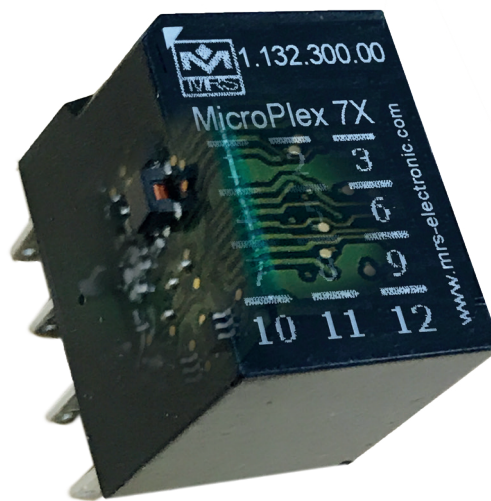

MANUFACTURER

MRS Electronic, Inc.  
6680 Poe Avenue Suite 100  
Dayton OH, 45414

NOTES ON WIRING AND CABLE ROUTING

Hightside outputs may only be switched to ground.

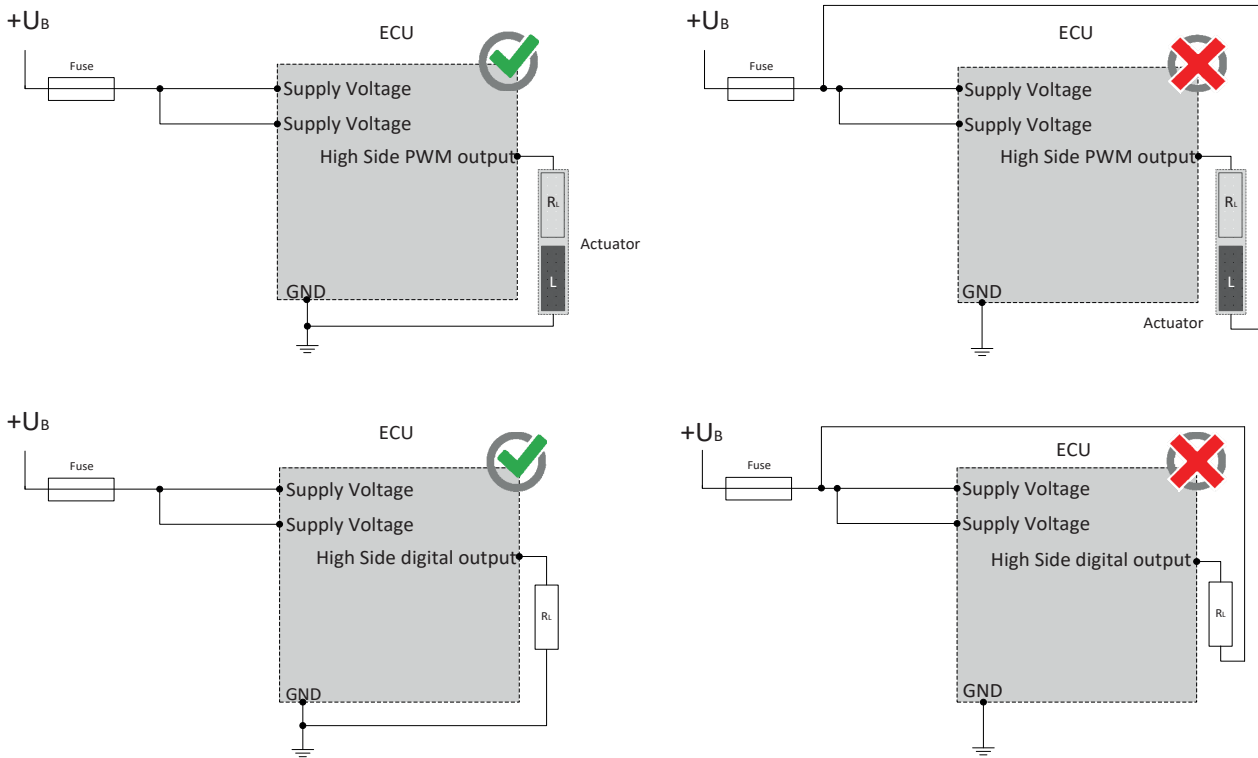

The sensor supplies can be “lifted” through an external circuitry, for example the creation of higher voltage, as they only work as a voltage source but not as voltage drain. The lift of a voltage source may lead to unforeseen malfunctions and damages of the control unit in case of permanent operation.

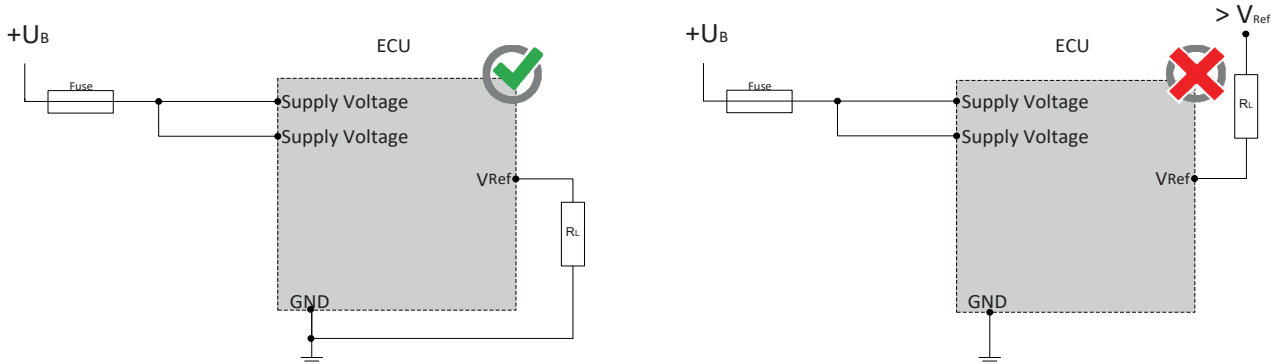

CAN bus communication is the main communication between the control unit and the vehicle. Therefore, connect the CAN bus with special care and check the correct communication with the vehicle to avoid undesired behavior.

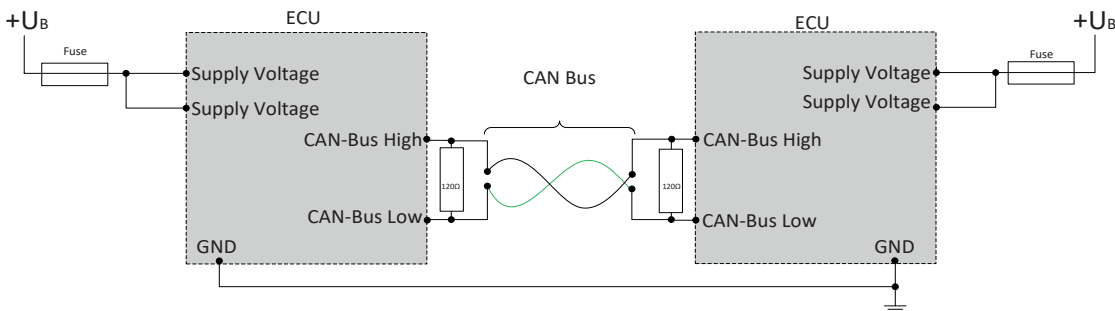



## SAFETY AND INSTALLATION INFORMATION

It is essential to read the instructions in full thoroughly before working with the device.

Please note and comply with the instructions in the operating instructions and the information in the device data sheet, see [www.mrs-electronic.com](http://www.mrs-electronic.com)

**Staff qualification:** Only staff with the appropriate qualifications may work on this device or in its proximity.

### SAFETY



**WARNING! Danger as a result of a malfunction of the entire system.**

Unforeseen reactions or malfunctions of the entire system may jeopardise the safety of people or the machine.

- Ensure that the device is equipped with the correct software and that the wiring and settings on the hardware are appropriate.



**WARNING! Danger as a result of unprotected moving components.**

Unforeseen dangers may occur from the entire system when putting the device into operation and maintaining it.

- Switch the entire system off before carrying out any work and prevent it from unintentionally switching back on.
- Before putting the device into operation, ensure that the entire system and parts of the system are safe.
- The device should never be connected or separated under load or voltage.



**CAUTION! Risk of burns from the housing.**

The temperature of the device housing may be elevated.

- Do not touch the housing and let all system components cool before working on the system.

### PROPER USE

The device is used to control or switch one or more electrical systems or sub-systems in motor vehicles and machines and may only be used for this purpose. The device may only be used in an industrial setting.



**WARNING! Danger caused by incorrect use.**

The device is only intended for use in motor vehicles and machines.

- Use in safety-related system parts for personal protection is not permitted.
- Do not use the device in areas where there is a risk of explosion.

**Correct use:**

- operating the device within the operating areas specified and approved in the associated data sheet.
- strict compliance with these instructions and no other actions which may jeopardise the safety of individuals or the functionality of the device.

**Obligations of the manufacturer of entire systems**

It is necessary to ensure that only functional devices are used. If devices fail or malfunction, they must be replaced immediately.

System developments, installation and the putting into operation of electrical systems may only be carried out by trained and experienced staff who are sufficiently familiar with the handling of the components used and the entire system.

It is necessary to ensure that the wiring and programming of the device does not lead to safety-related malfunctions of the entire system in the event of a failure or a malfunction. System behaviour of this type can lead to a danger to life or high levels of material damage.

The manufacturer of the entire system is responsible for the correct connection of the entire periphery (e.g. cable cross sections, correct selection/connection of sensors/actuators).

Opening the device, making changes to the device and carrying out repairs are all prohibited. Changes or repairs made to the cabling can lead to dangerous malfunctions. Repairs may only be carried out by MRS.

**Installation**

The installation location must be selected so the device is exposed to as low a mechanical and thermal load as possible. The device may not be exposed to any chemical loads.

Install the device in such a manner that the plugs point downwards. This means condensation can flow off the device. Single seals on the cables/leads must be used to ensure that no water gets into the device.

**Putting into operation**

The device may only be put into operation by qualified staff. This may only occur when the status of the entire system corresponds to the applicable guidelines and regulations.

### FAULT CORRECTION AND MAINTENANCE



**NOTE The device is maintenance-free and may not be opened.**

- If the device has damage to the housing, latches, seals or flat plugs, it must be taken out of operation.

Fault correction and cleaning work may only be carried out with the power turned off. Remove the device to correct faults and to clean it.

Check the integrity of the housing and all flat plugs, connections and pins for mechanical damage, damage caused by overheating, insulation damage and corrosion. In the event of faulty switching, check the software, switches and settings.

Do not clean the device with high pressure cleaners or steam jets. Do not use aggressive solvents or abrasive substances.