

DESCRIPTION

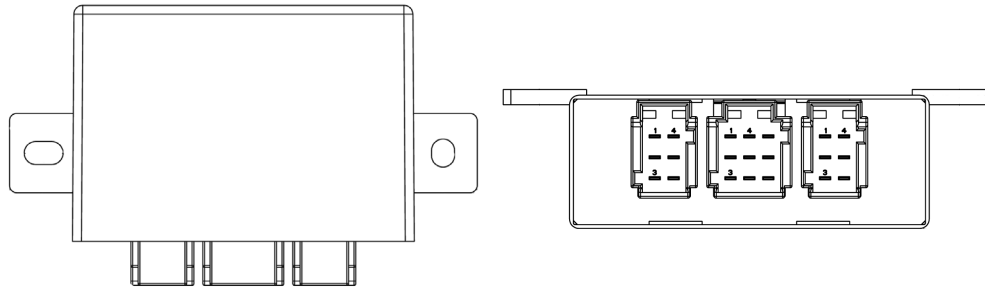

Mouting direction

View of plug

Motor control with 4x5 A motor outputs for DC motors and integrated current monitoring.  
 In many outdoor electronics applications, there is an increasing demand for small motor control units that can drive several DC motors cost-effectively via different bus systems. That is the point, where the 4-in-1 Motor Controller CAN comes into action.

TECHNICAL DATA

Housing	Plastic PA66 GF30
Connector	Tyco JPT 6- and 9-pin resp.
Weight	145 g
Temperature range acc. to ISO 16750-4	-40 °C...+85 °C (at +85 °C not full load)
Environmental protection acc. to ISO 20653	IP 53
Fuse protection	20 A
Total inputs and outputs	9
Inputs	<b>Configurable:</b> 1 analog input 0...6 V 1 analog input 0...33.6 V 1 analog input 0...5 V OR PT1000
Outputs	4 motor fullbridges 2 digital outputs
Supply voltage	9...32 V (Code C for 12V, Code E for 24 V, acc. to ISO 16750-2)
Oversvoltage protection	≥ 33 V
Current consumption	40 mA at 12 V 42 mA at 24 V
Quiescent current	12 V: 40 µA or 220 µA with LIN 24 V: 150 µA or 575 µA with LIN
Reverse polarity protection	integrated
CAN interfaces	CAN Interface 2.0 A/B, ISO 11898-2

REGULATORY APPROVALS AND TESTING

E1 approval	10 R – 06 7815
Electrical tests	<b>Acc. to ISO 16750-2 or -4:</b> Supply voltage Long term overvoltage at $T_{max}$ -20 °C Superimposed alternating voltage Momentary drop in supply voltage Reset behaviour at voltage drop Starting profile Reversed voltage Pin disconnection Connector disconnection Short circuit Storage test at $T_{min}$ and $T_{max}$ Operation test at $T_{min}$ and $T_{max}$ Temperature step test
	<b>Acc. to ISO 7637-2:</b> Pulse 1, 2a, 2b, 3a, 3b, severity level IV
	<b>Acc. to ISO 10605:</b> ESD up to ± 15 kV contact discharge ESD up to ± 15 kV air discharge
Chemical tests	<b>Acc. to ISO 16750-5:</b> AA, AB, AC, BA, BB, BC, BD, CA, CB, CC, CD, DB, DF, DG, EA

SOFTWARE/PROGRAMMING

Programming System

**MRS APPLICS STUDIO**

The Applics Studio is the new development and tool platform for our assemblies. Program your MRS controls quickly and easily with our stand-alone software. The focus is on your application.



INPUT FEATURES - SUMMARY

<b>Pin X103.4 (AI_01)</b>	Programmable as analog or digital input Resolution 12 Bit Accuracy $\leq 3\%$ full scale	<b>Pin X103.6 (AI_PT1000)</b>	Programmable as analog or digital input Resolution 12 Bit Accuracy $\pm 3\%$ full scale
Voltage input 0...6 V (see <a href="#">B</a> )	Input resistance 120 k $\Omega$ Input frequency $f_g^1 = 23$ Hz	Voltage input 0...5 V (see <a href="#">A</a> )	Input resistance 2.9 k $\Omega$ Input frequency $f_g^1 = 28$ Hz
<b>Pin X103.7 (AI_LIN)</b>	Programmable as analog or digital input Resolution 12 Bit Accuracy $\pm 3\%$ full scale	Sensor input PT1000 (see <a href="#">D</a> )	Input resistance 1 k $\Omega$ against 5VREF
Voltage input 0...33.6 V (see <a href="#">C</a> )	Input resistance 63 k $\Omega$ Input frequency $f_g^1 = 30$ Hz		

<sup>1</sup> Cutoff frequency (-3 dB)

OUTPUT FEATURES - SUMMARY

<b>Pin X101.1, X101.2, X101.3, X101.4, X102.1, X102.2, X102.3, X102.4</b>		<b>Pin X101.5, X102.5</b>	
Motor-output (see <a href="#">E</a> )	Switching voltage 9-32 V max. load current 5 A PWM frequency max. 1 kHz	Digital output (see <a href="#">E</a> )	Switching voltage 9-32 V max. load current 5 A
Short circuit protection against GND and $U_B$	Internal overtemperature protection, latch-off can be realized by software application	Short circuit protection against GND and $U_B$	Internal overtemperature protection, latch-off can be realized by software application
Overload protection	Internal overtemperature protection, latch-off can be realized by software application	Overload protection	Internal overtemperature protection, latch-off can be realized by software application





LOAD TEST AT  $T_{+85^\circ C}$  MOTOR-OUTPUT (FULLBRIDGE)

Test without PWM with resistive load	Test no.	Load	Duration
	1	4 outputs: 2.3 A	Permanent
	2	1 output: 4 A	Permanent

PIN ASSIGNMENT POWER SUPPLY AND INTERFACES

Pin	Description	Pin	Description
X101.6	KL31 / GND	X103.3	KL30 / Supply voltage
X102.6	KL31 / GND	X103.5	KL15 / Ignition
X103.1	CAN-H	X103.8	AI_5VREF
X103.3	CAN-L	X103.9	KL31 / GND

PIN ASSIGNMENT INPUTS AND OUTPUTS

Pin	Signal	Description	Pin	Signal	Description
X101.5	DO_HSD1 AI_SENSE_HSD1	Digital output with Current readback	X101.1	DO_REL_M1_POS	Full bridge 
X102.5	DO_HSD2 AI_SENSE_HSD2	Digital output with Current readback	X101.2	DO_REL_M1_NEG	
X103.4	AI_01	Analog input 01 0...6 V	X101.3	DO_REL_M2_POS	Full bridge 
X103.6	AI_PT1000	Analog input 0...5 V PT1000 activated via AI_5VREF (DO_EN_VREF)	X101.4	DO_REL_M2_NEG	
X103.7	AI_LIN	Analog input 0...33.6 V		DO_HSD_M12	Activation of the full bridge M1 and M2
X103.8	AI_5VREF	5V reference, activated via DO_EN_VREF		DO_PWM_LSD_M12	Activation of the PWM of the full bridge M1 and M2
				AI_INA_M12	INA current sense full bridge M1 and M2
			X102.1	DO_REL_M3_POS	Full bridge 
			X102.2	DO_REL_M3_NEG	
			X102.3	DO_REL_M4_POS	Full bridge 
			X102.4	DO_REL_M4_NEG	
				DO_HSD_M34	Activation of the full bridge M3 and M4
				DO_PWM_LSD_M34	Activation of the PWM of the full bridge M3 and M4
				AI_INA_M34	INA current sense full bridge M3 and M4

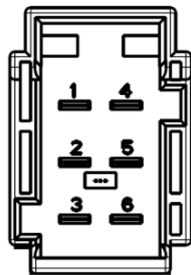

Pin assignment X101 und X102

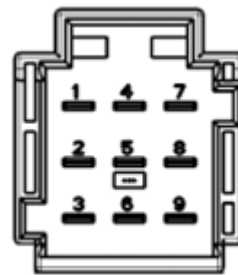

Pin assignment X103

PIN - OVERVIEW

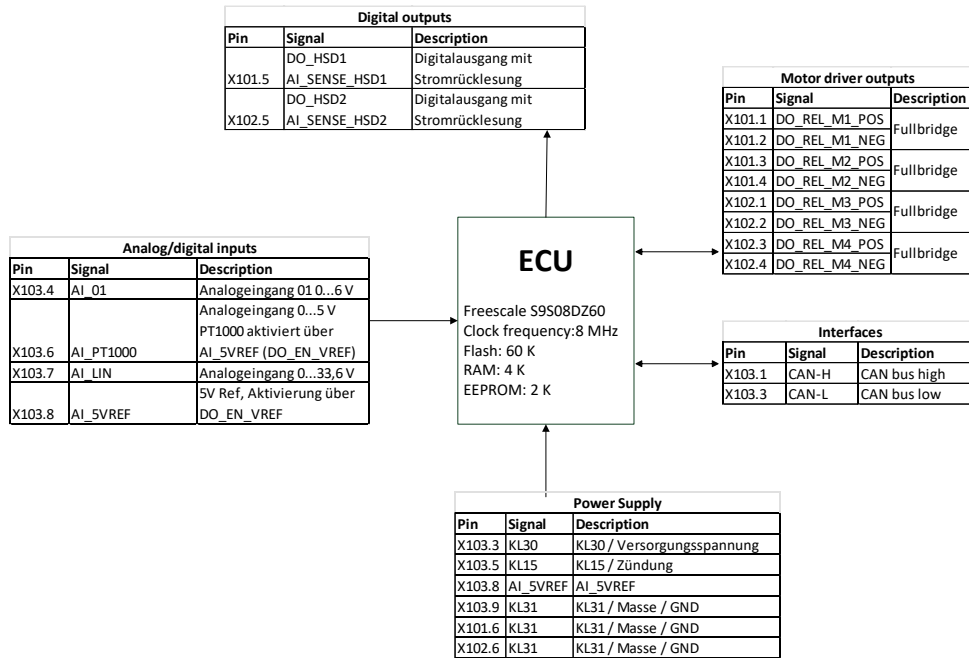

BLOCK FUNCTION DIAGRAM

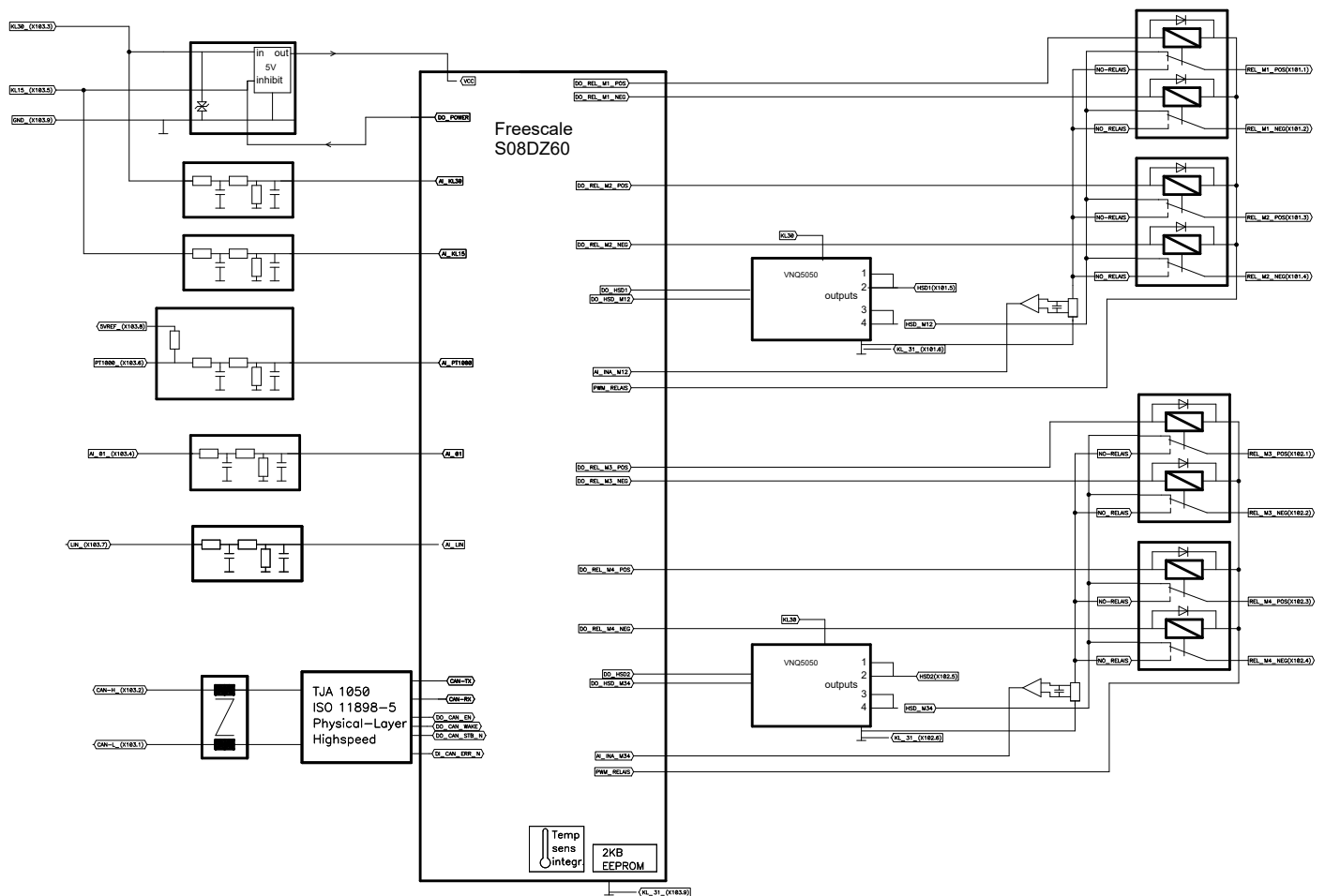

TECHNICAL DRAWING IN MM [INCH], TOLERANCES ACCORDING TO ISO 2768-1 V

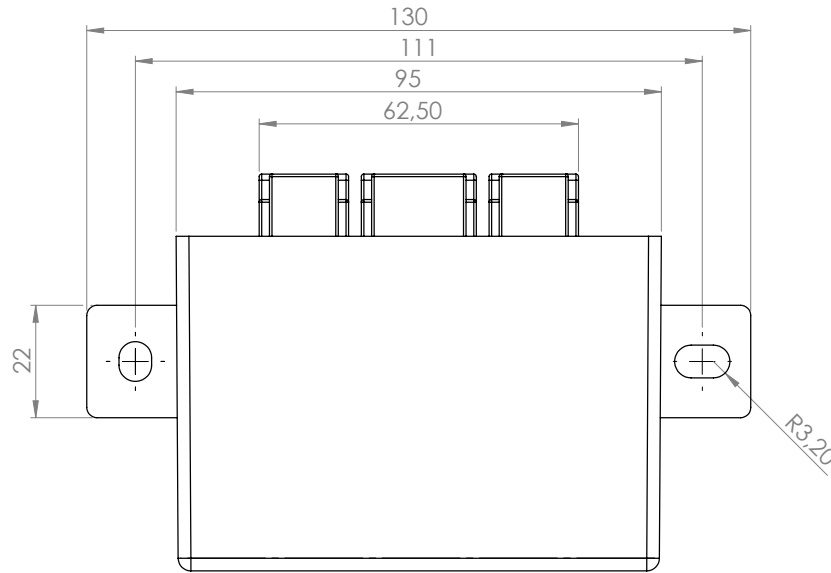

Side view

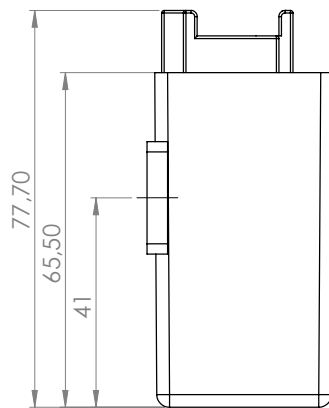

Side view

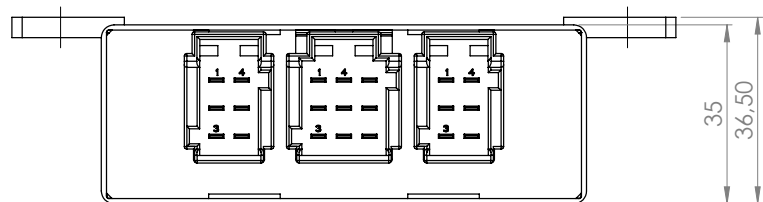

Bottom view



ASSEMBLY VARIANTS AND ORDERING INFORMATIONS

	Inputs numbering				Outputs numbering		Wake up sources	Interfaces
	A Voltage input 0...5 V	B Voltage input 0...6 V	C Voltage input 0...33,6 V	D Sensor input PT1000	E Motor outputs	F Digital outputs		CAN Bus
<b>1.122.300.00</b>	X103.6	X103.4	X103.7	X103.6	X101.1, X101.2, X101.3, X101.4, X102.1, X102.2, X102.3, X102.4	X101.5, X102.5	KL15, DO_POWER	X103.1, X103.2

ACCESORIES

Description	Order number
Programming tool MRS Applics Studio	1.100.200.01
Cable set for programming	500349
Connector package	300187
PCAN-USB Interface	105358



MANUFACTURER

MRS Electronic, Inc.  
6680 Poe Avenue Suite 100  
Dayton OH, 45414  
USA

NOTES ON WIRING AND CABLE ROUTING

Highside outputs may only be switched to ground.

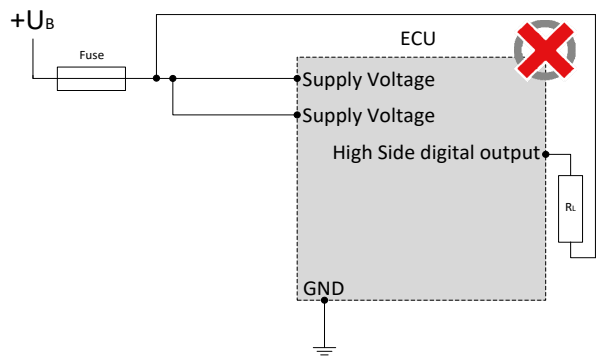
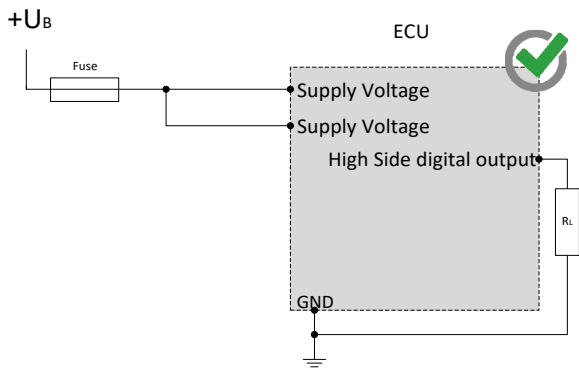
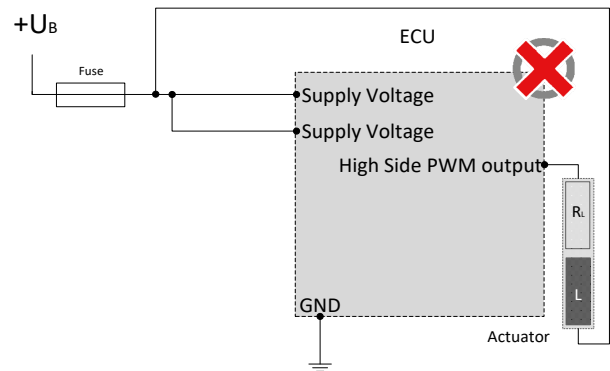
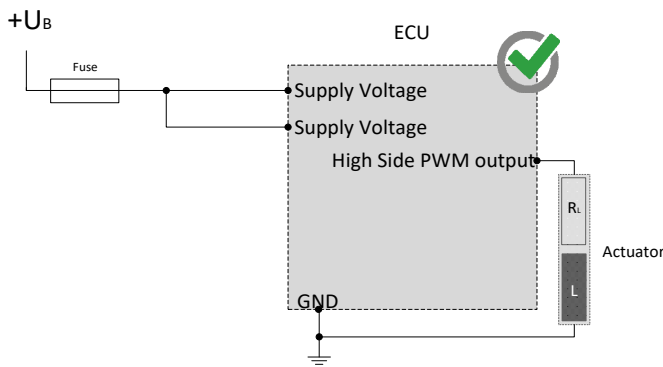

The sensor supplies can be “lifted” through an external circuitry, for example the creation of higher voltage, as they only work as a voltage source but not as voltage drain. The lift of a voltage source may lead to unforeseen malfunctions and damages of the control unit in case of permanent operation.

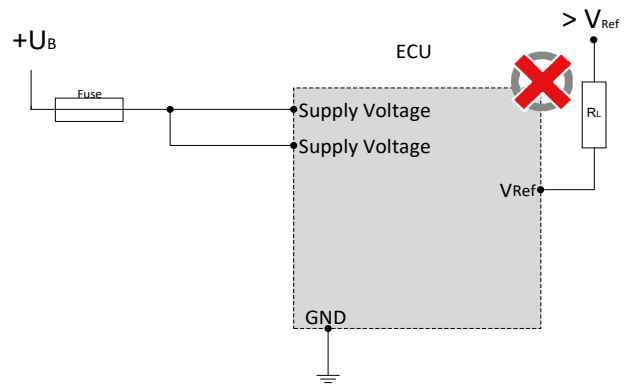
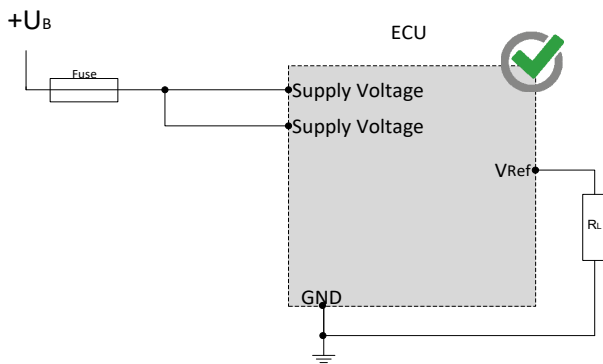

NOTES ON WIRING AND CABLE ROUTING

CAN bus communication is the main communication between the control unit and the vehicle. Therefore, connect the CAN bus with special care and check the correct communication with the vehicle to avoid undesired behavior.

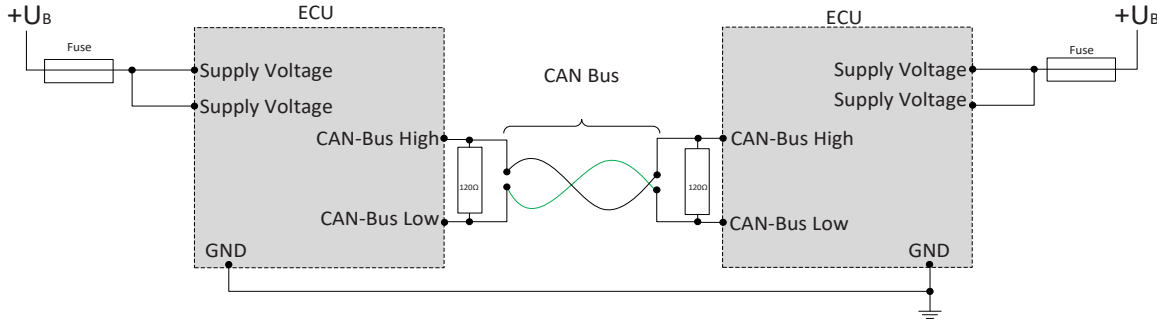

The full bridge motor outputs may only be interconnected against each other.

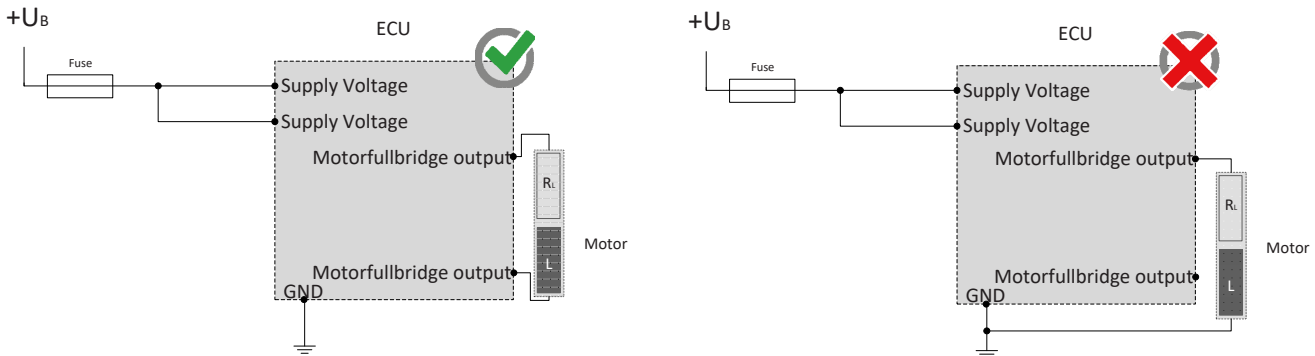

The controller must be appropriately protected against overload (see performance data)

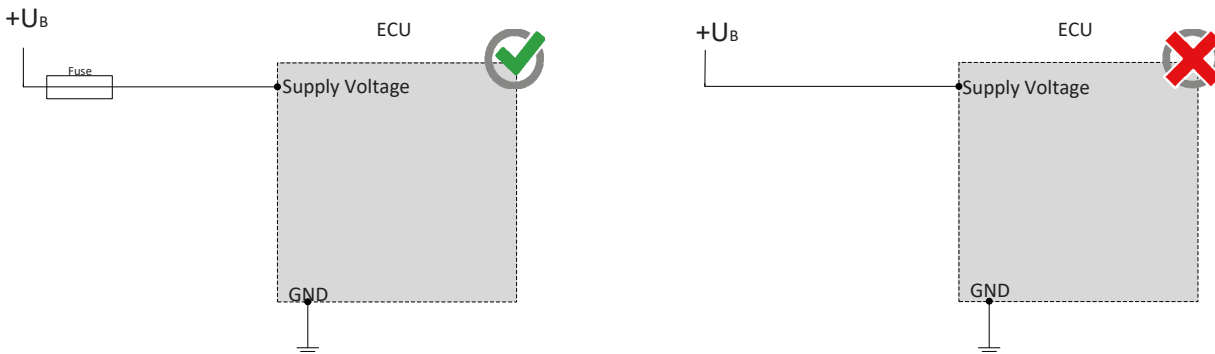

To prevent damage to the hardware, a ramp function, e.g. via the graphic programming block "Ramp", must be used. The description for this is stored in the Applies Studio.

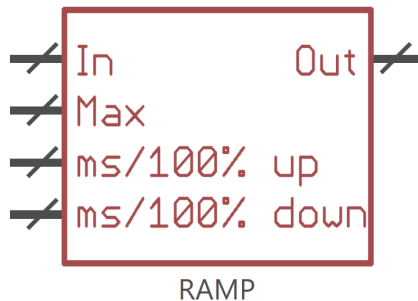

## SAFETY AND INSTALLATION INFORMATION

It is essential to read the instructions in full thoroughly before working with the device.

Please note and comply with the instructions in the operating instructions and the information in the device data sheet, see [www.mrs-electronic.com](http://www.mrs-electronic.com)

**Staff qualification:** Only staff with the appropriate qualifications may work on this device or in its proximity.

### SAFETY



**WARNING! Danger as a result of a malfunction of the entire system.**

Unforeseen reactions or malfunctions of the entire system may jeopardise the safety of people or the machine.

- Ensure that the device is equipped with the correct software and that the wiring and settings on the hardware are appropriate.



**WARNING! Danger as a result of unprotected moving components.**

Unforeseen dangers may occur from the entire system when putting the device into operation and maintaining it.

- Switch the entire system off before carrying out any work and prevent it from unintentionally switching back on.
- Before putting the device into operation, ensure that the entire system and parts of the system are safe.
- The device should never be connected or separated under load or voltage.



**CAUTION! Risk of burns from the housing.**

The temperature of the device housing may be elevated.

- Do not touch the housing and let all system components cool before working on the system.

### PROPER USE

The device is used to control or switch one or more electrical systems or sub-systems in motor vehicles and machines and may only be used for this purpose. The device may only be used in an industrial setting.



**WARNING! Danger caused by incorrect use.**

The device is only intended for use in motor vehicles and machines.

- Use in safety-related system parts for personal protection is not permitted.
- Do not use the device in areas where there is a risk of explosion.

**Correct use:**

- operating the device within the operating areas specified and approved in the associated data sheet.
- strict compliance with these instructions and no other actions which may jeopardise the safety of individuals or the functionality of the device.

**Obligations of the manufacturer of entire systems**

It is necessary to ensure that only functional devices are used. If devices fail or malfunction, they must be replaced immediately.

System developments, installation and the putting into operation of electrical systems may only be carried out by trained and experienced staff who are sufficiently familiar with the handling of the components used and the entire system.

It is necessary to ensure that the wiring and programming of the device does not lead to safety-related malfunctions of the entire system in the event of a failure or a malfunction. System behaviour of this type can lead to a danger to life or high levels of material damage.

The manufacturer of the entire system is responsible for the correct connection of the entire periphery (e.g. cable cross sections, correct selection/connection of sensors/actuators).

Opening the device, making changes to the device and carrying out repairs are all prohibited. Changes or repairs made to the cabling can lead to dangerous malfunctions. Repairs may only be carried out by MRS.

**Installation**

The installation location must be selected so the device is exposed to as low a mechanical and thermal load as possible. The device may not be exposed to any chemical loads.

Install the device in such a manner that the plugs point downwards. This means condensation can flow off the device. Single seals on the cables/leads must be used to ensure that no water gets into the device.

**Putting into operation**

The device may only be put into operation by qualified staff. This may only occur when the status of the entire system corresponds to the applicable guidelines and regulations.

### FAULT CORRECTION AND MAINTENANCE



**NOTE The device is maintenance-free and may not be opened.**

- If the device has damage to the housing, latches, seals or flat plugs, it must be taken out of operation.

Fault correction and cleaning work may only be carried out with the power turned off. Remove the device to correct faults and to clean it.

Check the integrity of the housing and all flat plugs, connections and pins for mechanical damage, damage caused by overheating, insulation damage and corrosion. In the event of faulty switching, check the software, switches and settings.

Do not clean the device with high pressure cleaners or steam jets. Do not use aggressive solvents or abrasive substances.