

mounting direction

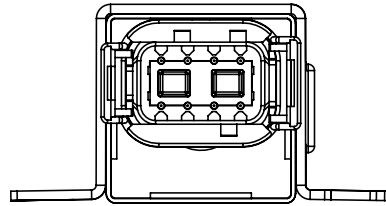

view of plug

DESCRIPTION

The Micro PLC CAN 4 ANA offers many possible applications with its 5 inputs and outputs. One analog input and four I/Os, the function of which can be individually defined. These inputs/outputs can be used as four analog outputs for current (0-24mA) and voltages (0-10V). Or you can configure them as four analog inputs.

TECHNICAL SPECIFICATION

Housing	PA66GF30 plastic
Connector	DEUTSCH DTM04-08PA
Weight	28 g
Temperature range (according to ISO 16750-4)	-40 °C to +85 °C
Environmental protection	IP 6K8, when watertight socket is used and the mounting direction is correct
Current consumption	35 mA (at 12 V) 40 mA (at 24 V)
Over-current Protection	Current consumption + load current
Total Inputs and outputs	4
Inputs	Configurable as: Analog (0...11.4 V/0...33.7 V) Current input (0...24 mA) Frequency input
Outputs	Configurable as: Constant voltage source Analog voltage output
Operating voltage	9-32 V
Overvoltage protection	≥ 33 V
Quiescent current	20 µA (bei 12 V und 24 V)
Reverse polarity protection	Yes
CAN Interfaces	Highspeed 2.0 A/B according to ISO 11898-2

REGULATORY APPROVALS AND TESTING

E1 approval	ECE R10 05 7522
Electrical tests	Acc. to ISO 16750-2: Short Circuit supply I/O lines Reverse Polarity Interrupt Pin Break plug Jump Start
	Acc. to ISO 16750-4: Long-term overvoltage at 65 °c Storage Test Tmax and Tmin Operations Test Tmax and Tmin
	Acc. to ISO 7637: Transient pulses 1 to 4 acc. to ECE R10
	Acc. to ISO 10605: ESD Pins: ± 10 kV ESD Housing: ± 8 kV ESD indirect discharge: ± 15 kV

SOFTWARE/PROGRAMMING

Programming System

MRS Developers Studio

MRS Developers Studio with built-in functions library, similar programming with FUP. Custom software blocks can be integrated into "C-code". Program memory is sufficient for about 300 basic logic components.



INPUT FEATURES - SUMMARY

Pin 5, 8			Pin 2, 3		
Usable as analog or digital input			Usable as analog or digital input		
	Resolution	12 Bit		Resolution	12 Bit
	Accuracy	1% full scale		Accuracy	1% full scale
Voltage input 0...11.4 V (see "A")	Input resistance	29 kΩ	Voltage input 0...11.4 V (see "A")	Input resistance	54 kΩ
	Input frequency	$f_g=30$ Hz		Input frequency	$f_g=30$ Hz
	Accuracy	± 3 %		Accuracy	± 3 %
	Conversion factor	3 (33 Digits≈ 100 mV, S.5)		Conversion factor	3 (33 Digits≈ 100 mV, S.5)
Voltage input 0...33.6 V (see "B")	Input resistance	500 Ω	Voltage input 0...33.6 V (see "B")	Input resistance	54 kΩ
	Input frequency	$f_g=75$ Hz		Input frequency	$f_g=75$ Hz
	Accuracy	± 3 %		Accuracy	± 3 %
	Conversion factor	8,8 (12 Digits≈ 100 mV, S.5)		Conversion factor	8.8 (12 Digits≈ 100 mV, S.5)
Digital input	Input resistance	29 kΩ	Digital input	Input resistance	54 kΩ
	Turn-on threshold (11.4 V)	7 V		Turn-on threshold (11.4 V)	7 V
	Turn-off threshold (11.4 V)	5.5 V		Turn-off threshold (11.4 V)	5.5 V
	Turn-on threshold (33.6 V)	20.5 V		Turn-on threshold (33.6 V)	20.5 V
	Turn-off threshold (33.6 V)	15.6 V		Turn-off threshold (33.6 V)	15.6 V
Current input 0...24 mA (see "C")	Input resistance	500 Ω	Current input 0...24 mA (see "C")	Input resistance	500 Ω
	Conversion factor	≈0,0175 (580 Digits≈ 10 mA, S.5)		Conversion factor	≈0,0175 (580 Digits≈ 10 mA, S.5)
Frequency input (see "D") ²	Input resistance	29 kΩ	¹ cutoff frequency (-3 dB) ² When programming via C-code, both frequency inputs can be read in parallel.		
	Accuracy	Up to 5 kHz max. ± 3 %			
	Turn-on threshold (11.4 V)	7 V			
	Turn-off threshold (11.4 V)	5.5 V			
	Turn-on threshold (33.6 V)	20.5 V			
	Turn-off threshold (33.6 V)	15.6 V			

CONFIGURATION OF INPUTS

Desired Configuration	Setting via
Voltage input 0-11.4 V AI_NAME	DO_I_NAME = 0, DO_30V_10V_NAME = 0, PWM_20MA_NAME = 0
Voltage input 0-33.6 V AI_NAME	DO_I_NAME = 0, DO_30V_10V_NAME = 1, PWM_20MA_NAME = 0
Analog voltage output / current input	Set: DO_I_NAME = 1, PWM_20MA_NAME (0-100% = 0-UB _{-3V})
Current output	Set: DO_I_NAME = 0, PWM_20MA_NAME (0-100% = 0-22 mA)
Frequency input (X and C)	Reading of the input frequency via FREQ_NAME

OUTPUT FEATURES - SUMMARY

Pin 2,3,5,8

Digital, positive switching	Switching voltage	UB _{-3V}
	Switching current	25 mA
	Analog voltage output	Deviation ± 3 %

PIN ASSIGNMENT POWER SUPPLY AND INTERFACES

Pin	Pin description	Pin	Pin description
1	Ground	6	CAN - L
4	contact 30 / supply voltage	7	CAN - H

PIN ASSIGNMENT INPUTS AND OUTPUTS

Pin	Programm signal	Pin description	Pin	Programm signal	Pin description	
2	DI_87A	Digitale input 87A	5	DI_X	Digital input X	
	AI_87A	Analog input 87A		AI_X	Analog input X	
	DO_30V_10V_87A	Range selection 11.4/33.6 V		DO_30V_10V_X	Range selection 11.4/33.6 V	
	DO_I_87A	Current sink 87A		DO_I_X	Current sink X	
	PWM_20MA_87A	Current output 87A		PWM_20MA_X	Current output X	
		Analog voltage output			Analog voltage output	
					FREQ_X	Frequency input X
3	DI_87	Digital input 87	8	DI_C	Digital input C	
	AI_87	Analog input 87		AI_C	Analog input C	
	DO_30V_10V_87	Range selection 11.4/33.6 V		DO_30V_10V_C	Range selection 11.4/33.6 V	
	DO_I_87	Current sink 87		DO_I_C	Current sink C	
	PWM_20MA_87	Current output 87		PWM_20MA_C	Current output C	
		Analog voltage output			Analog voltage output	
					FREQ_C	Frequency input C

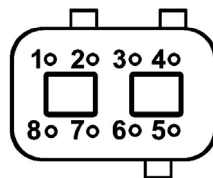

Bottom view

PIN FEATURE MAP

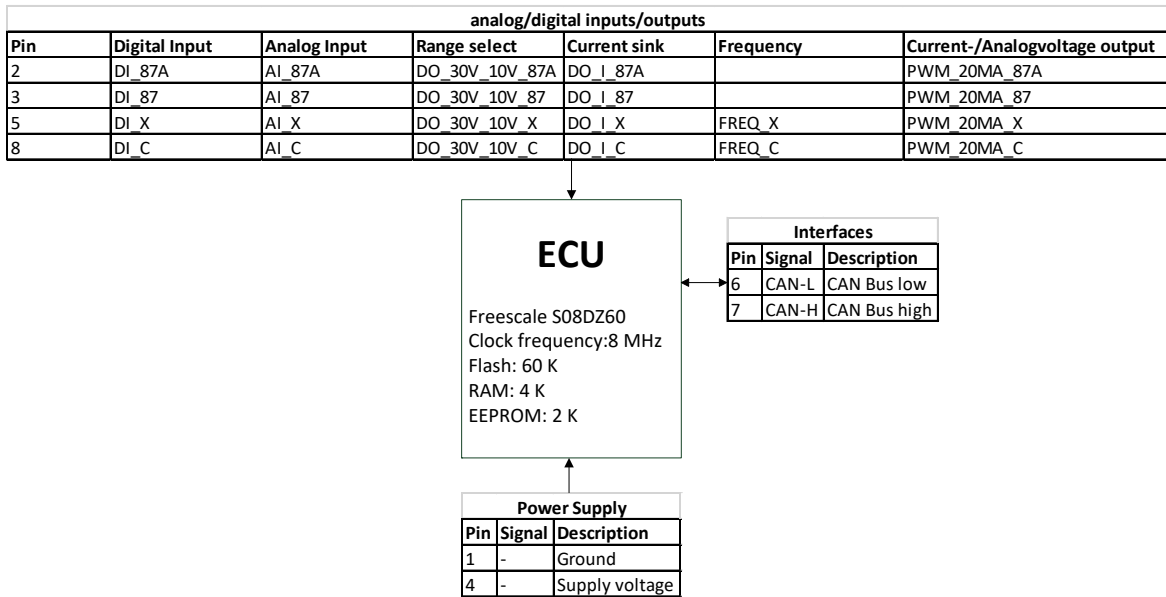

BLOCK FUNCTION DIAGRAM

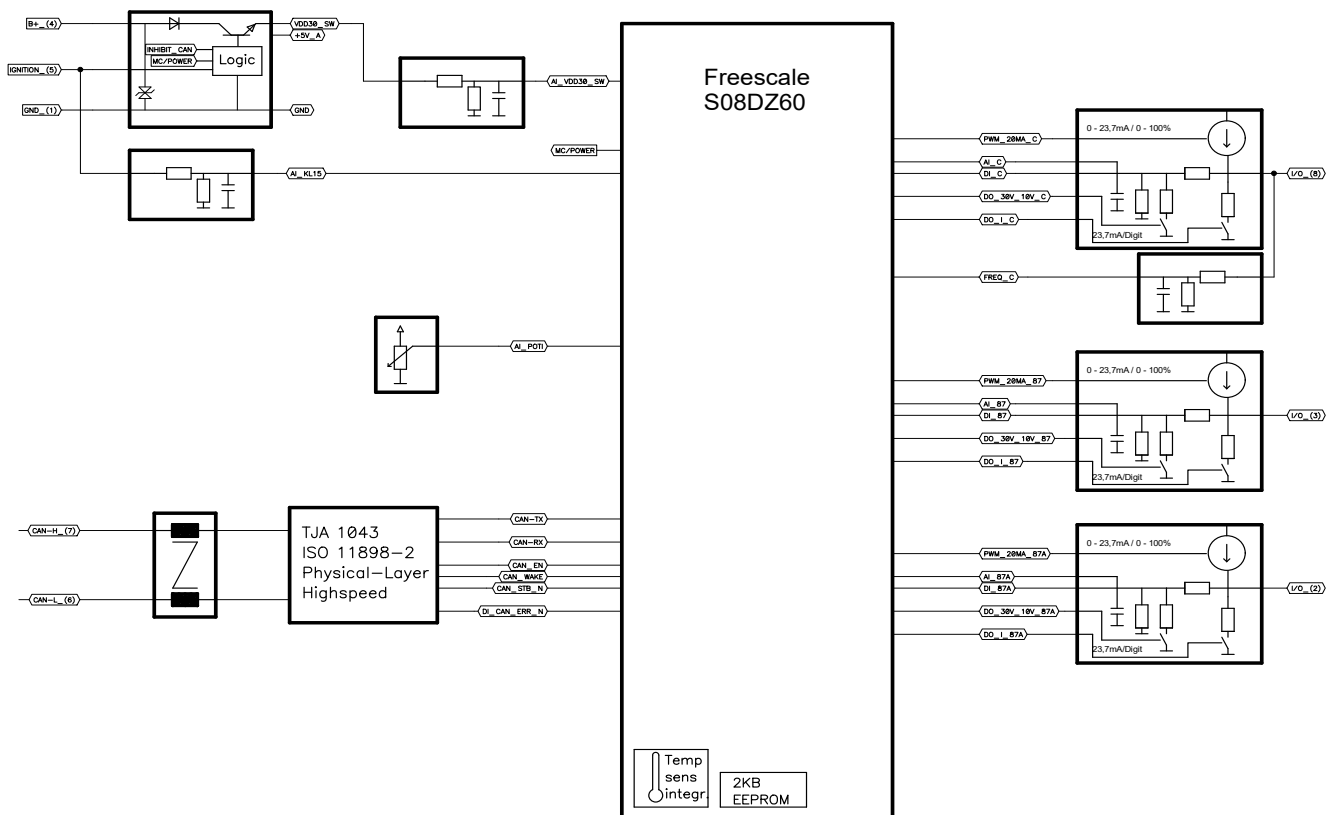

TECHNICAL DRAWING IN MM [INCH]

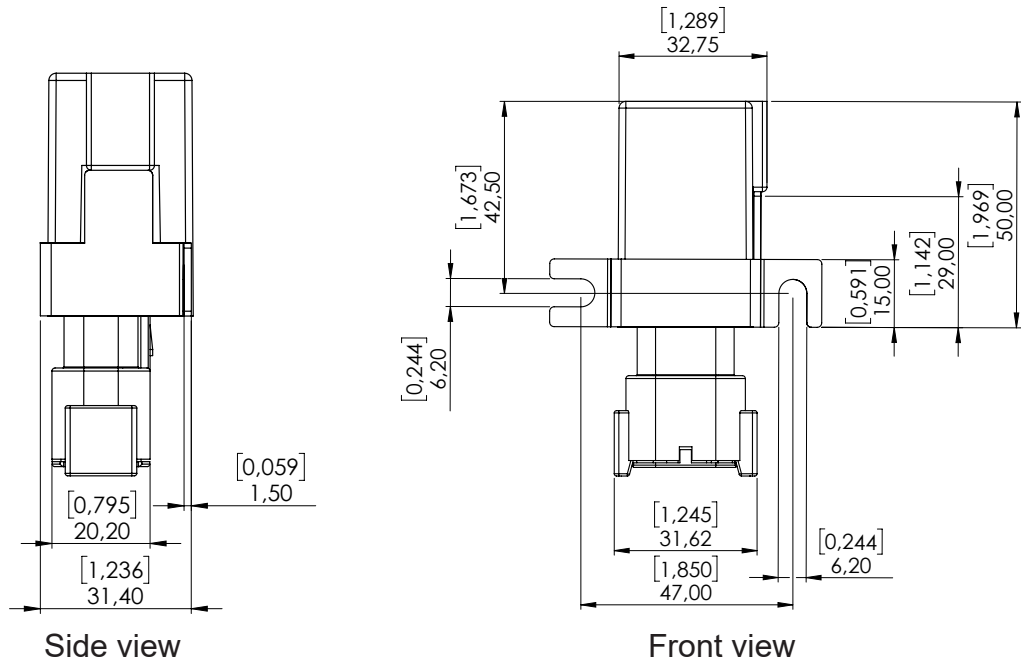

CONVERSION FACTOR

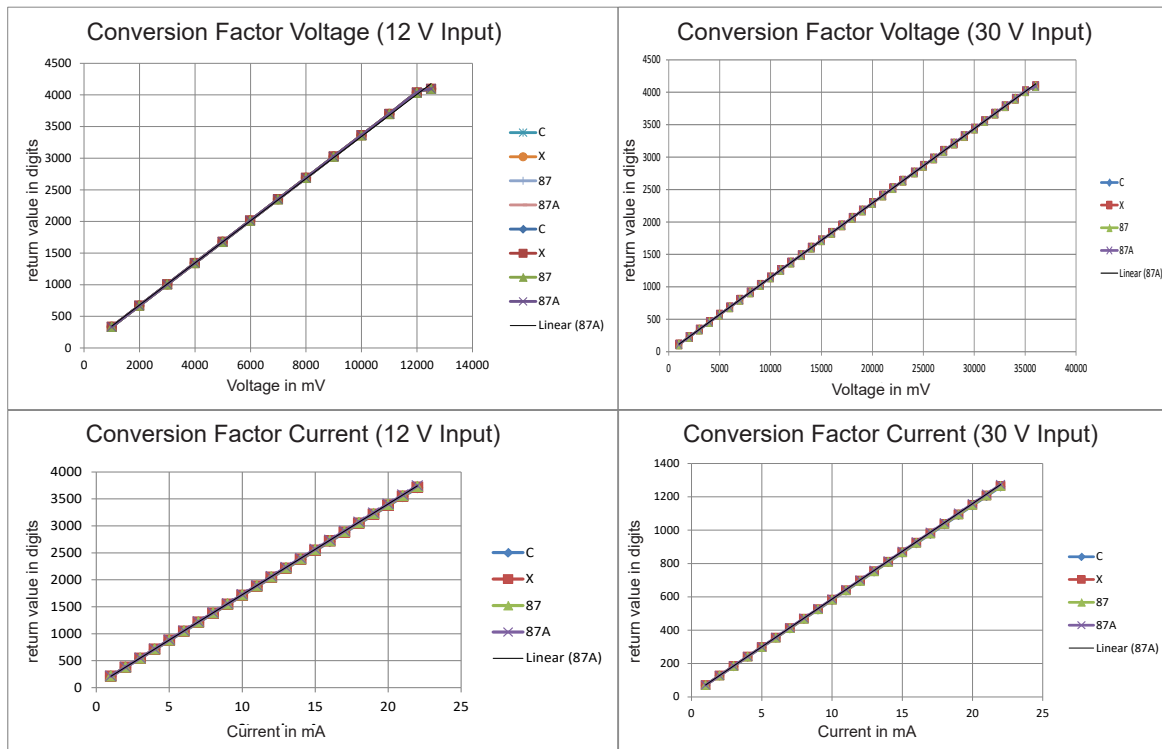



ASSEMBLY OPTIONS AND ORDER INFORMATION

Order number	Pin numbering of the inputs				CAN Bus		Remarks
	A Voltage	B Voltage	C Current	D Frequency	High-Speed	Low-Speed	
	0 – 11.4 V	0 – 33.6 V	0 - 24 mA	0 - 5.5 kHz			
1.112.902.00	2,3,5,8	2,3,5,8	2,3,5,8	5,8	X		

ACCESSORIES

Description	Order number
Programming tool MRS Developers Studio	1.100.100.09



Image similar

MANUFACTURER

MRS Electronic, Inc.
6680 Poe Avenue Suite 100
Dayton OH, 45414
USA

NOTES ON WIRING AND CABLE ROUTING

CAN bus communication is the main communication between the control unit and the vehicle. Therefore, connect the CAN bus with special care and check the correct communication with the vehicle to avoid undesired behavior.

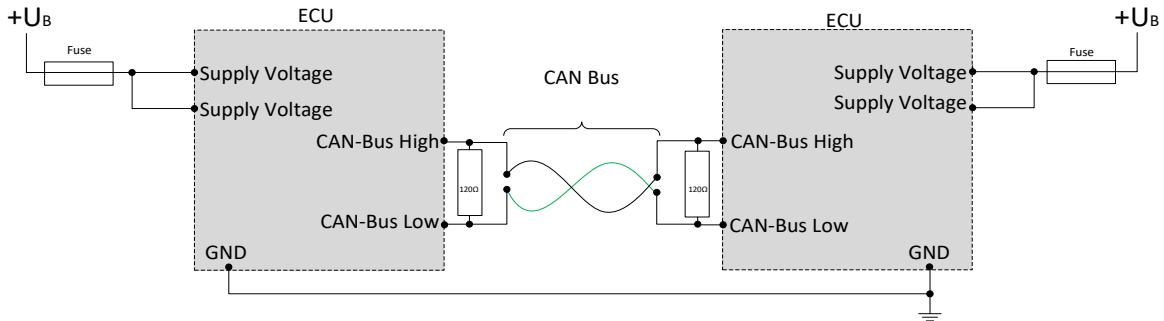

The control must be protected against overload (see performance data)

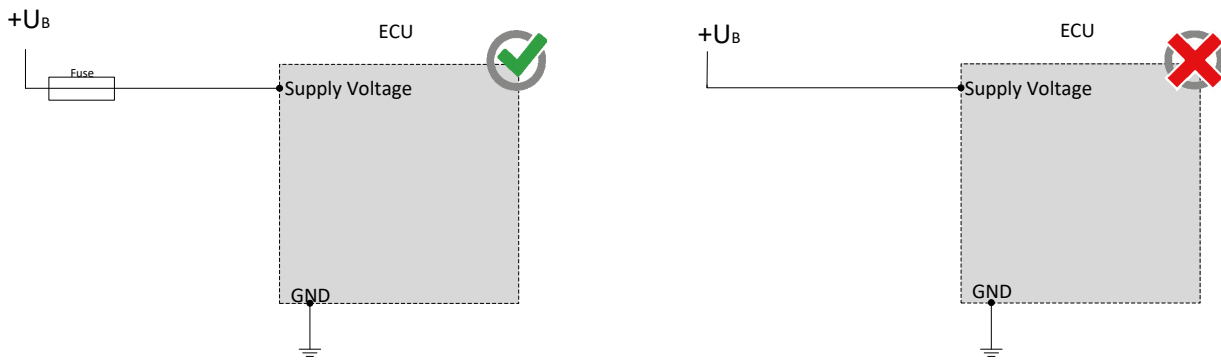

SAFETY AND INSTALLATION INFORMATION

It is essential to read the instructions in full thoroughly before working with the device.

Please note and comply with the instructions in the operating instructions and the information in the device data sheet, see www.mrs-electronic.com

Staff qualification: Only staff with the appropriate qualifications may work on this device or in its proximity.

SAFETY



WARNING! Danger as a result of a malfunction of the entire system.

Unforeseen reactions or malfunctions of the entire system may jeopardise the safety of people or the machine.

- Ensure that the device is equipped with the correct software and that the wiring and settings on the hardware are appropriate.



WARNING! Danger as a result of unprotected moving components.

Unforeseen dangers may occur from the entire system when putting the device into operation and maintaining it.

- Switch the entire system off before carrying out any work and prevent it from unintentionally switching back on.
- Before putting the device into operation, ensure that the entire system and parts of the system are safe.
- The device should never be connected or separated under load or voltage.



CAUTION! Risk of burns from the housing.

The temperature of the device housing may be elevated.

- Do not touch the housing and let all system components cool before working on the system.

PROPER USE

The device is used to control or switch one or more electrical systems or sub-systems in motor vehicles and machines and may only be used for this purpose. The device may only be used in an industrial setting.



WARNING! Danger caused by incorrect use.

The device is only intended for use in motor vehicles and machines.

- Use in safety-related system parts for personal protection is not permitted.
- Do not use the device in areas where there is a risk of explosion.

Correct use:

- operating the device within the operating areas specified and approved in the associated data sheet.
- strict compliance with these instructions and no other actions which may jeopardise the safety of individuals or the functionality of the device.

Obligations of the manufacturer of entire systems

It is necessary to ensure that only functional devices are used. If devices fail or malfunction, they must be replaced immediately.

System developments, installation and the putting into operation of electrical systems may only be carried out by trained and experienced staff who are sufficiently familiar with the handling of the components used and the entire system.

It is necessary to ensure that the wiring and programming of the device does not lead to safety-related malfunctions of the entire system in the event of a failure or a malfunction. System behaviour of this type can lead to a danger to life or high levels of material damage.

The manufacturer of the entire system is responsible for the correct connection of the entire periphery (e.g. cable cross sections, correct selection/connection of sensors/actuators).

Opening the device, making changes to the device and carrying out repairs are all prohibited. Changes or repairs made to the cabling can lead to dangerous malfunctions. Repairs may only be carried out by MRS.

Installation

The installation location must be selected so the device is exposed to as low a mechanical and thermal load as possible. The device may not be exposed to any chemical loads.

Install the device in such a manner that the plugs point downwards. This means condensation can flow off the device. Single seals on the cables/leads must be used to ensure that no water gets into the device.

Putting into operation

The device may only be put into operation by qualified staff. This may only occur when the status of the entire system corresponds to the applicable guidelines and regulations.

FAULT CORRECTION AND MAINTENANCE



NOTE The device is maintenance-free and may not be opened.

- If the device has damage to the housing, latches, seals or flat plugs, it must be taken out of operation.

Fault correction and cleaning work may only be carried out with the power turned off. Remove the device to correct faults and to clean it.

Check the integrity of the housing and all flat plugs, connections and pins for mechanical damage, damage caused by overheating, insulation damage and corrosion. In the event of faulty switching, check the software, switches and settings.

Do not clean the device with high pressure cleaners or steam jets. Do not use aggressive solvents or abrasive substances.