

mounting direction

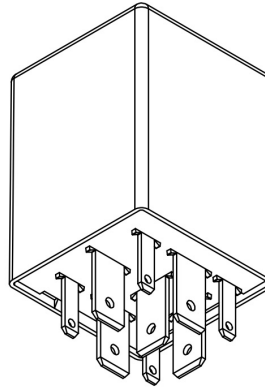

side view

## DESCRIPTION

The Micro PLC CAN 4 I/O is a very small controller for automotive applications. The module is user configurable / programmable for a wide range of automotive applications. Control and data readout is via CAN bus.

## TECHNICAL SPECIFICATION

Housing	Plastic PA66GF30
Connector	9-in bottom panel
Weight	28 g
Temperature range acc. to ISO 16750-4	-40 °C...+85 °C (at +85 °C not full load)
Environmental protection acc. to ISO 20653	IP 6K8, when watertight socket is used and the mounting direction is correct
Current consumption	24 mA (12 V); 26 mA (24 V)
Over-current Protection	10 A
Total Inputs and outputs	4 inputs/outputs (I/Os), 1 digital input
Inputs	<b>Configurable as:</b> Analog (0...11.4 V) Digital, positive encoder signals
Outputs	<b>Configurable as:</b> Digital, positiv switching (High-Side) PWM output (3 Hz...500 Hz)
Supply voltage	9...32 V (Code C for 12 V, Code E for 24 V, acc. to ISO 16750-2)
Overvoltage protection	≥ 33 V
Quiescent current	300 µA (12 V); 460 µA (24 V)
Reverse polarity protection	yes
CAN Interfaces	CAN Interface 2.0 A/B ISO 11898-2:2006

## REGULATORY APPROVALS AND TESTING

E1 approval	10 R - 06 7199
Electrical tests	<b>Acc. to ISO 16750-2 or -4:</b> Reverse Polarity Short circuit Long term overvoltage at T <sub>+60 °C</sub> Storage Test at T <sub>+85 °C</sub> and T <sub>-40 °C</sub> Operation Test at T <sub>-40 °C</sub> Superimposed alternating voltage Slow decrease and increase of the supply voltage Reset behavior at voltage drop Noise emission/immunity to ECE R10 Rev. 04 Cable-led interference emission to ECE R10 Rev. 04
	<b>Acc. to ISO 7637-2:</b> Pulse 1, 2a, 2b, 3a, 3b and 4

## SOFTWARE/PROGRAMMING

### Programming System

#### MRS APPLICS STUDIO

The Applics Studio is the new development and tool platform for our assemblies. Program your MRS controls quickly and easily with our stand-alone software. The focus is on your application.



INPUT FEATURES - SUMMARY

Pin 1, 3, 5, 8	Usable as analog or digital input		Pin 4	Usable as analog or digital input	
	Resolution	12 Bit		Resolution	12 Bit
	Accuracy	±1 % full scale		Accuracy	±1 % full scale
Voltage input 0...11.4 V (see <a href="#">A</a> )	Input resistance	17.6 kΩ	Voltage input 0...11.4 V (see <a href="#">A</a> )	Input resistance	22.6 kΩ
	Input frequency	60 Hz		Input frequency	60 Hz
	Accuracy	±3 %		Accuracy	±3 %
Digital input Positive (see <a href="#">B</a> )	Input resistance	17.6 kΩ	Digital input Positive (see <a href="#">A</a> )	Input resistance	22.6 kΩ
	Input frequency			Input frequency	
	Turn-on threshold	6.5 V		Turn-on threshold	6.5 V
	Turn-off threshold	4.9 V		Turn-off threshold	4.9 V

<sup>1</sup> cutoff frequency (-3 dB)

OUTPUT FEATURES - SUMMARY

Pin 1, 3, 5, 8	Protective circuit for inductive loads	integrated
	Wire fault diagnostics	Possible via current sense
	Short circuit diagnostics	Possible via current sense
Digital, positive switching (high side; see <a href="#">B</a> )	Switching voltage	9...32 V DC
	Switching current	0.02...2.5 A
	Internal current sense	Via signal AI_I_87, AI_I_87A, AI_I_C, AI_I_X To obtain calibrated values, the directive #define ADC_CAL_ENABLE must be set in the header file user_code.h. Calibrated values can be activated / deactivated via ALG_CAL_STATE in MRS Applics Studio
PWM-output (see <a href="#">C</a> )	Output frequency	3...500 Hz
	Duty cycle	0...1000 ‰
	Resolution	1 ‰
	Switching current	up to 2.5 A frequency set via one timer channel, duty cycle selectable per output
Short circuit protection against GND and U <sub>B</sub>	Internal overtemperature protection, latch-off can be realized by software application	

PERFORMANCE TEST OUTPUTS AT T<sub>MAX</sub>

Test without PWM	Test No.	Load	Duration
	1	4 x 2 A	permanent
	2	1 x 2.5 A (87A); 2 x 1 A (X, 87)	30 min
	3	1 x 3 A (87)	15 min

PIN ASSIGNMENT POWER SUPPLY AND INTERFACES

Pin	Pin description	Pin	Pin description
2	Contact 30 / Supply voltage	7	CAN-H
4	Contact 15 / battery / ignition / analog or digital input	9	CAN-L
6	Contact 31 / Ground		

PIN ASSIGNMENT INPUTS AND OUTPUTS

Pin	Programm signal	Pin description	Pin	Programm signal	Pin description
1	X	Analog/digital input X 0...11.4 V or digital output X with PWM option and read off current	5	87A	Analog/digital input 87A 0...11.4 V or digital output 87A with PWM option and read off current
3	C	Analog/digital input C 0...11.4 V or digital output C with PWM option and read off current	8	87	Analog/digital input 87 0...11.4 V or digital output 87 with PWM option and read off current

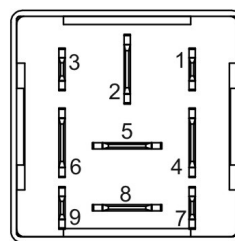

bottom view

PIN FEATURE MAP

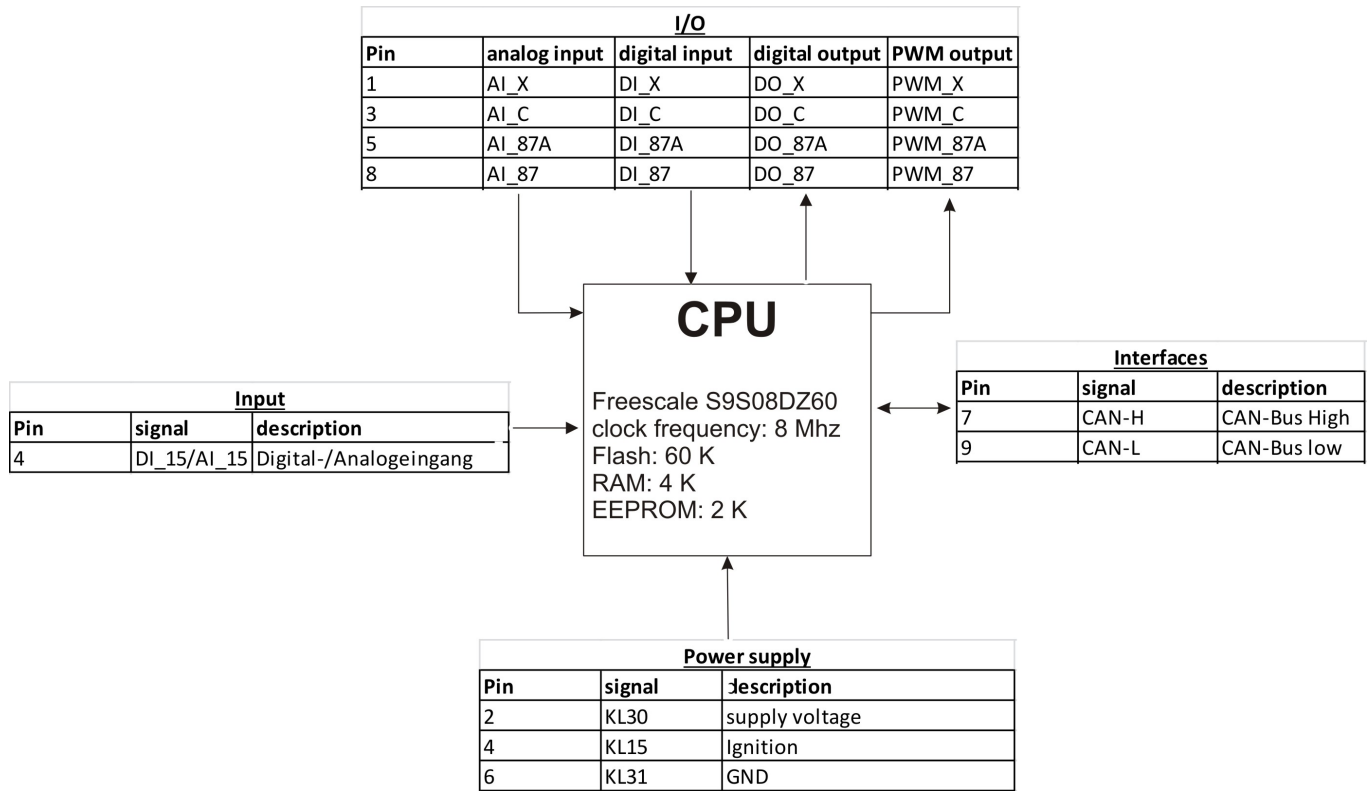

BLOCK FUNCTION DIAGRAM

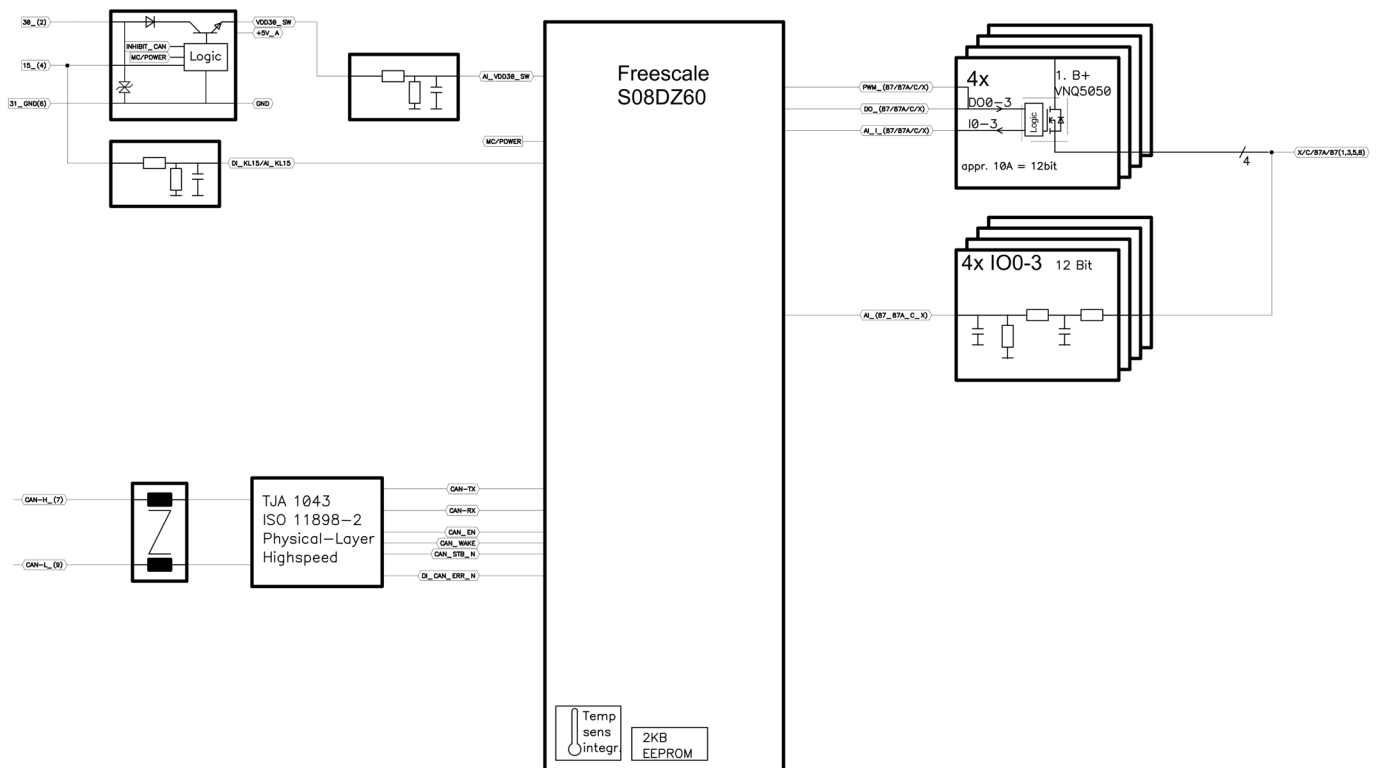

TECHNICAL DRAWING IN MM [INCH], TOLERANCES ACCORDING TO ISO 2768-1 V

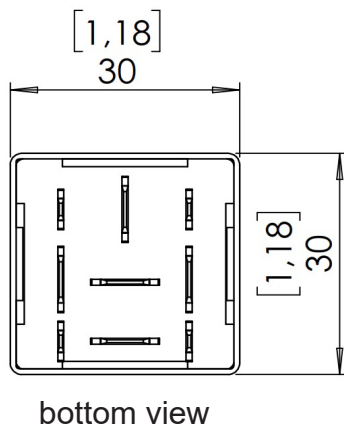
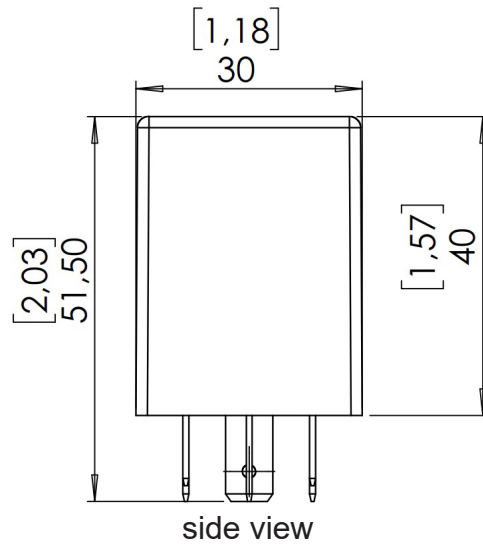



ASSEMBLY OPTIONS AND ORDER INFORMATION

	Inputs		Outputs	CAN Bus		Remarks	SCIP number
	A Voltage 0...11.4 V	B I/O's (optional as analog/digital input or digital output)	C PWM ≤ 500 Hz	High-Speed	Low-Speed		
<b>1.111.311.00</b>	1, 3, 5, 8	1, 3, 5, 8	1, 3, 5, 8	X			85e9f145-6c86-4b38-b2d2-f608a0d0ab03
<b>1.111P.311.00</b>	1, 3, 5, 8	1, 3, 5, 8	1, 3, 5, 8	X		CANopen	3ea205e7-bed9-4427-b4bb-644f59e7de2b

ACCESSORIES

Description	Order number
Softwaretool MRS Applics Studio	1.100.200.01
Socket ST FL 9-pin 5x6.3 / 4x2.8	1.017.002.00
Socket package watertight 40 mm	1.017.010.40
Cable set to programm Micro PLC CAN / Prop CAN	109446
FASTON terminal for latching 6.3 mm 1.5-2.5 mm <sup>2</sup>	103064
FASTON terminal for latching 6.3 mm 1 mm <sup>2</sup>	102355
FASTON terminal for latching 2.8 mm 0.5-1.0 mm <sup>2</sup>	105292
Housing bracket	1.017.080.00
PCAN-USB Interface	105358



MANUFACTURER

MRS Electronic, Inc.  
 6680 Poe Avenue Suite 100  
 Dayton OH, 45414  
 USA

NOTES ON WIRING AND CABLE ROUTING

PWM outputs may not be connected with each other or bypassed.

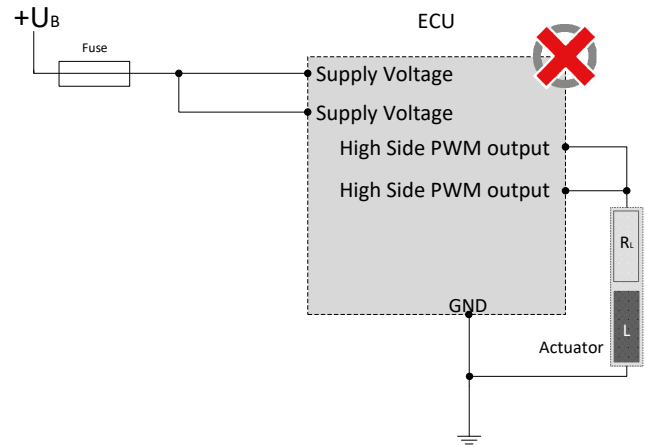
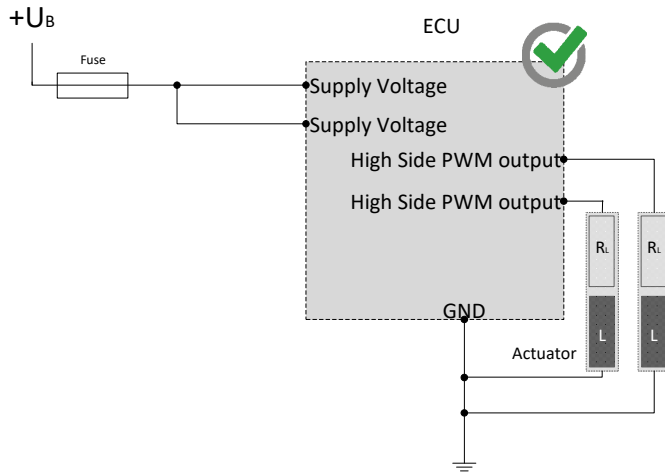

The pins (I/Os) can be used in combination and may not be switched externally against supply voltage.

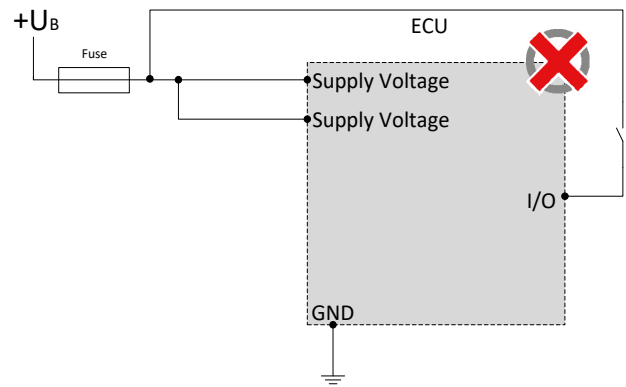
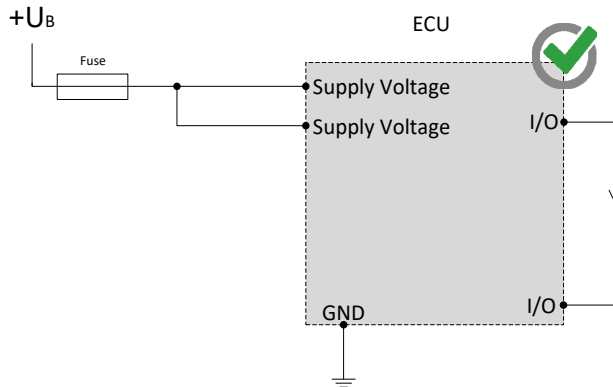

The pins (I/Os) can be used in combination and may not be switched externally against a higher voltage level than supply voltage.

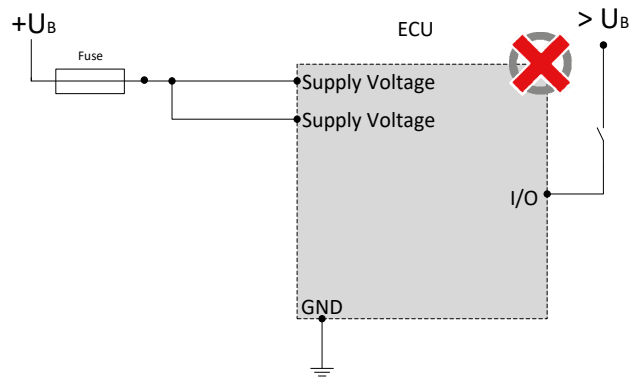
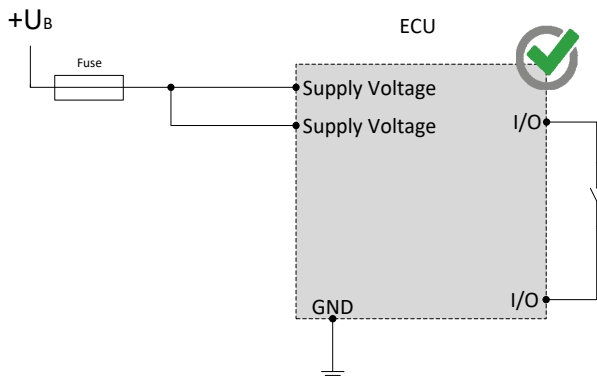

NOTES ON WIRING AND CABLE ROUTING

Hightside outputs may only be switched to ground.

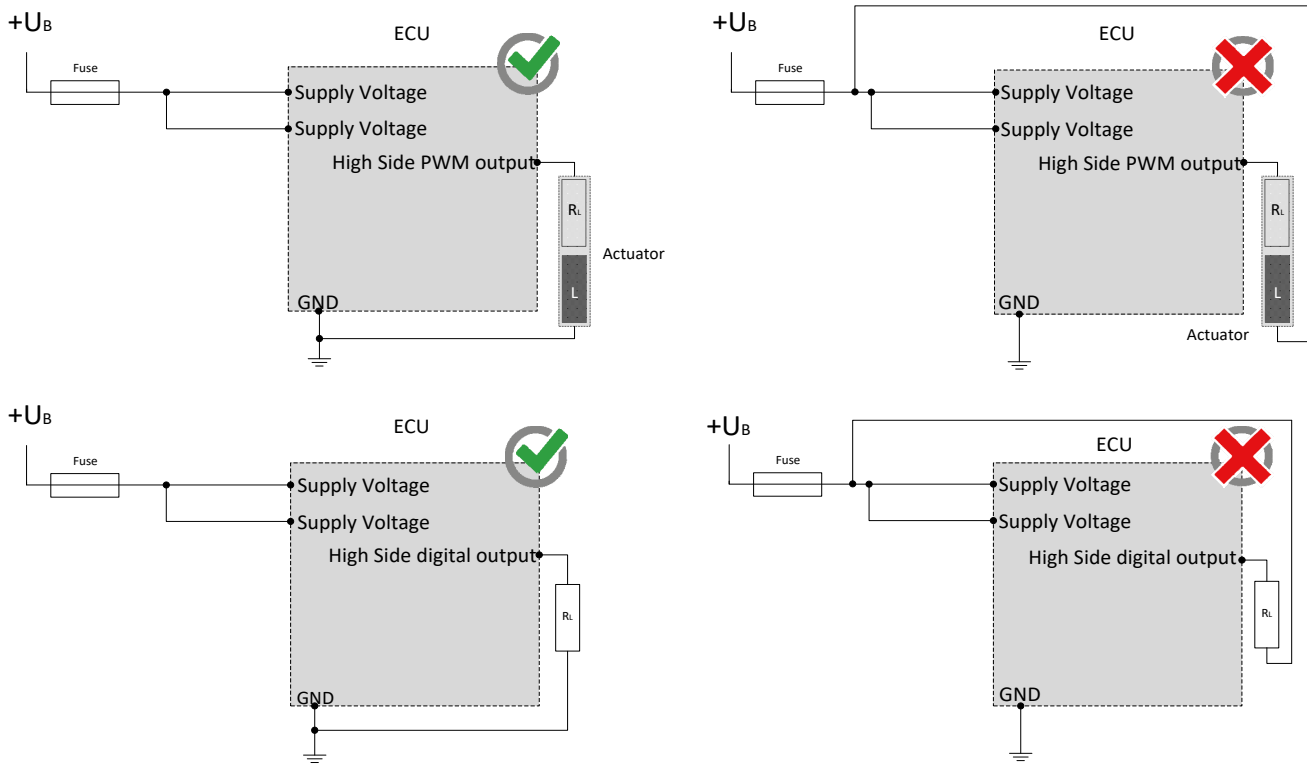

CAN bus communication is the main communication between the control unit and the vehicle. Therefore, connect the CAN bus with special care and check the correct communication with the vehicle to avoid undesired behavior.

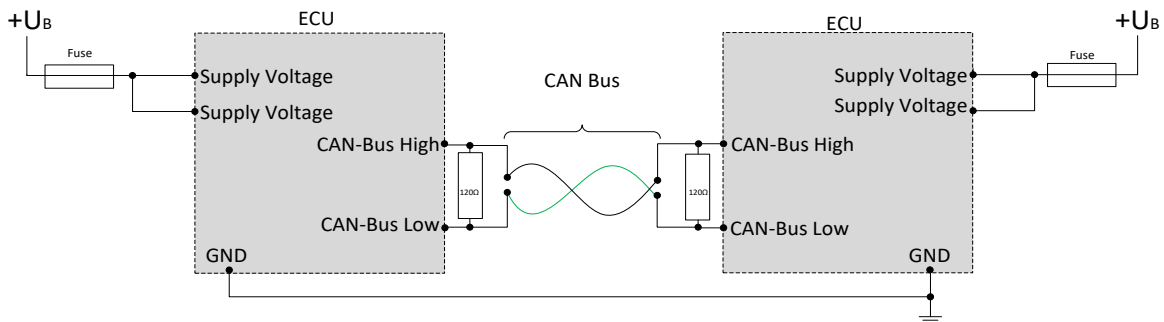

## SAFETY AND INSTALLATION INFORMATION

It is essential to read the instructions in full thoroughly before working with the device.

Please note and comply with the instructions in the operating instructions and the information in the device data sheet, see [www.mrs-electronic.com](http://www.mrs-electronic.com)

**Staff qualification:** Only staff with the appropriate qualifications may work on this device or in its proximity.

### SAFETY



**WARNING! Danger as a result of a malfunction of the entire system.**

Unforeseen reactions or malfunctions of the entire system may jeopardise the safety of people or the machine.

- Ensure that the device is equipped with the correct software and that the wiring and settings on the hardware are appropriate.



**WARNING! Danger as a result of unprotected moving components.**

Unforeseen dangers may occur from the entire system when putting the device into operation and maintaining it.

- Switch the entire system off before carrying out any work and prevent it from unintentionally switching back on.
- Before putting the device into operation, ensure that the entire system and parts of the system are safe.
- The device should never be connected or separated under load or voltage.



**CAUTION! Risk of burns from the housing.**

The temperature of the device housing may be elevated.

- Do not touch the housing and let all system components cool before working on the system.

### PROPER USE

The device is used to control or switch one or more electrical systems or sub-systems in motor vehicles and machines and may only be used for this purpose. The device may only be used in an industrial setting.



**WARNING! Danger caused by incorrect use.**

The device is only intended for use in motor vehicles and machines.

- Use in safety-related system parts for personal protection is not permitted.
- Do not use the device in areas where there is a risk of explosion.

**Correct use:**

- operating the device within the operating areas specified and approved in the associated data sheet.
- strict compliance with these instructions and no other actions which may jeopardise the safety of individuals or the functionality of the device.

**Obligations of the manufacturer of entire systems**

It is necessary to ensure that only functional devices are used. If devices fail or malfunction, they must be replaced immediately.

System developments, installation and the putting into operation of electrical systems may only be carried out by trained and experienced staff who are sufficiently familiar with the handling of the components used and the entire system.

It is necessary to ensure that the wiring and programming of the device does not lead to safety-related malfunctions of the entire system in the event of a failure or a malfunction. System behaviour of this type can lead to a danger to life or high levels of material damage.

The manufacturer of the entire system is responsible for the correct connection of the entire periphery (e.g. cable cross sections, correct selection/connection of sensors/actuators).

Opening the device, making changes to the device and carrying out repairs are all prohibited. Changes or repairs made to the cabling can lead to dangerous malfunctions. Repairs may only be carried out by MRS.

**Installation**

The installation location must be selected so the device is exposed to as low a mechanical and thermal load as possible. The device may not be exposed to any chemical loads.

Install the device in such a manner that the plugs point downwards. This means condensation can flow off the device. Single seals on the cables/leads must be used to ensure that no water gets into the device.

**Putting into operation**

The device may only be put into operation by qualified staff. This may only occur when the status of the entire system corresponds to the applicable guidelines and regulations.

### FAULT CORRECTION AND MAINTENANCE



**NOTE The device is maintenance-free and may not be opened.**

- If the device has damage to the housing, latches, seals or flat plugs, it must be taken out of operation.

Fault correction and cleaning work may only be carried out with the power turned off. Remove the device to correct faults and to clean it.

Check the integrity of the housing and all flat plugs, connections and pins for mechanical damage, damage caused by overheating, insulation damage and corrosion. In the event of faulty switching, check the software, switches and settings.

Do not clean the device with high pressure cleaners or steam jets. Do not use aggressive solvents or abrasive substances.