

Mouting direction

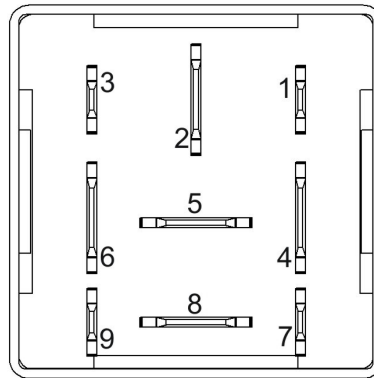

View of plug

## DESCRIPTION

The Micro PLC CAN is a small control system for automotive applications. Free configuration and programmability offer a wide range of applications in the automotive sector. Control and readout are done via the CAN bus (ISO 11898-2). Freescale Processor with Flash technology (option of multiple programming).

## TECHNICAL DATA

Housing	Plastic PA66GF30
Connector	Base plate 9-pin
Weight	31 g
Ambient temperature acc. to ISO 16750-4	-40 °C...+85 °C
Environmental protection acc. to ISO 20653	IP40 with potentiometer; IP6K8 without potentiometer and with watertight socket
Current consumption	27 mA
Protection	<b>Depending on the assembly variant:</b> cf. p. 7/8
Total inputs and outputs	<b>Depending on the assembly variant:</b> See p. 7/8
Inputs	<b>Depending on the assembly variant:</b> Analogue input (0...11.4 V) Digital, positive encoder signal frequency input
Outputs	<b>Depending on the assembly variant:</b> Digital, positive switching (high-side or relay output) PWM output (3...500 Hz)
Supply voltage	<b>Depending on the assembly variant:</b> 12 V (Code C) and/or 24 V (Code F) ISO 16750-2 compliant
Overvoltage protection	≥ 33 V
Quiescent current	<b>Depending on the assembly variant:</b> See p. 7/8
Reverse polarity protection	yes
CAN interfaces	CAN bus interface 2.0 A/B, ISO 11898-2:2003 compliant

## REGULATORY APPROVALS AND TESTINGS

E1 Approval	10 R - 06 7362
Electrical tests	<b>According to ISO 16750-2 or -4:</b> Short circuit protection Jump-start (12 V variants) Reverse polarity test Interruption pin und plug Long-term overvoltage at $T_{max}$ -20 °C Storage test at $T_{max}$ and $T_{min}$ Operation test at $T_{max}$ and $T_{min}$ Overlaying AC voltage Low sink and rise of supply voltage Voltage drop Reset behaviour at voltage drop
	<b>According to ISO 7637-2:</b> Pulse 1, 2a, 2b, 3a, 3b

## SOFTWARE/PROGRAMMING

### Programming System

#### MRS APPLICS STUDIO

The Applies Studio is the new development and tool platform for our assemblies. Program your MRS controls quickly and easily with our stand-alone software. The focus is on your application.

INPUT FEATURES - SUMMARY

Pin X (1)			Pin 15 (4) <sup>2</sup>		
Usable as analog or digital input			Usable as analog or digital input		
Resolution			Resolution		
Accuracy			Accuracy		
12 Bit			12 Bit		
± 1% full scale			± 1% full scale		
Voltage input 0...11.4 V (see <a href="#">A</a> )	Input resistance	22,6 kΩ	Voltage input 0...11.4 V (see <a href="#">A</a> )	Input resistance	21,4 kΩ
	Input frequency	fg <sup>1</sup> = 60 Hz		Input frequency	fg <sup>1</sup> = 65 Hz
	Accuracy	± 2 %		Accuracy	± 10 %
Digital input positiv (see <a href="#">C</a> )	Input resistance	22,6 kΩ	Voltage input 0...33.6 V (see <a href="#">features</a> )	Input resistance	65 kΩ
	Input frequency	fg <sup>1</sup> = 60 Hz		Input frequency	fg <sup>1</sup> = 46 Hz
	Turn-on threshold	6,5 V		Accuracy	± 10 %
	Turn-off threshold	5 V	Digital input positiv (see <a href="#">C</a> )	Input resistance	21,4 kΩ
Frequency input (see <a href="#">B</a> )	Input resistance	22,6 kΩ		Input frequency	fg <sup>1</sup> = 65 Hz
	Input frequency	bis ≤ 2.2 kHz		Turn-on threshold	6,7 V
	Turn-on threshold	6,5 V		Turn-off threshold	6,6 V
	Turn-off threshold	5 V	<b>Pin C (3)</b>		
Usable as analog or digital input			Usable as analog or digital input		
Resolution			Resolution		
Accuracy			Accuracy		
12 Bit			12 Bit		
± 1% full scale			± 1% full scale		
only assembly variant A			Voltage input 0...11.4 V (see <a href="#">A</a> )	Input resistance	21,4 kΩ
				Input frequency	fg <sup>1</sup> = 65 Hz
				Accuracy	± 2 %
			Digital input positiv (see <a href="#">C</a> )	Input resistance	21,4 kΩ
				Input frequency	fg <sup>1</sup> = 65 Hz
				Turn-on threshold	6,5 V
				Turn-off threshold	5 V

<sup>1</sup> cutoff frequency (-3 dB)

OUTPUT FEATURES - SUMMARY

Pin 87, 87A Relais variant			Pin 87, 87A Highside-Treiber Variante VNQ5050		
Load current at 23 °C (Relay, see <a href="#">D</a> )	NO (normally open)	15 A	Wire fault diagnostics	Possible via current sense	
	NC (normally closed)	10 A	Short circuit diagnostics	Possible via current sense	
Load current at 85 °C (Relay, see <a href="#">D</a> )	NO (normally open)	10 A	Digital, positive switching (High-Side; see <a href="#">E</a> )	Switching voltage	9-32 V DC
	NC (normally closed)	5 A		Switching current	<a href="#">see performance test</a>
	Fuse protection	max. 15 A		Current feedback	(ANA_I_OUT_87A ANA_I_OUT_87)
<b>Pin C</b>	Protection for inductive loads	not available, must be fused externally (free-wheeling diode)	Short circuit protection against GND and U <sub>B</sub>	Internal overtemperature protection, latch-off can be realized by software application	
Digital output (open collector output)	max. power	2 W <sup>3</sup>			

<sup>2</sup> For variants with quiescent current and activated DO\_POWER or CAN INH, the values may differ.

<sup>3</sup> When using an LED, it glows due to the leakage current even when switched off.

CONTINUOUS OUTPUT TEST HIGH-SIDE DRIVER VNQ5050 AT T<sub>MAX</sub> = 85 °C

Measurement No.	87	87a	Total current	Pass
1	2,5 A	2,5 A	5 A	yes
2	3,5 A	3,5 A	7 A	yes
3	4 A	4 A	8 A	yes
4	4,5 A	4,5 A	9 A	yes
5	3 A	5 A	8 A	yes
6	6 A	2 A	8 A	yes
7	5 A	5 A	10 A	no, not suitable for long term

PIN ASSIGNMENT SUPPLY VOLTAGE AND INTERFACES

Pin	Pin Description	Pin	Pin Description
2	supply voltage	6	Mass/GND
4	Battery/ignition contact 15 according to DIN 72552/ analog-digital input	7	CAN-Bus High
		9	CAN-Bus Low

PIN ASSIGNMENT IN- AND OUTPUTS

Pin	Programm signal	Pin Description	Pin	Programm signal	Pin Description
1	ANA_X D_ANA_X	Analog/ digital input X 0-11,4 V or Frequency input (configuration variant)	4	ANA_15 D_ANA_15	Analog/ digital input 15 0-11.4V
3	ANA_C D_ANA_C C	Analog/ digital input C 0-11,4 V or Digital output C (max 2W)	5	OUT_87A	NC output relays or HSD with configuration variant VNQ5050: Current feedback
			8	OUT_87	NO output relays or HSD with configuration variant VNQ5050: Current feedback
				ANA_I_OUT_87	Current feedback

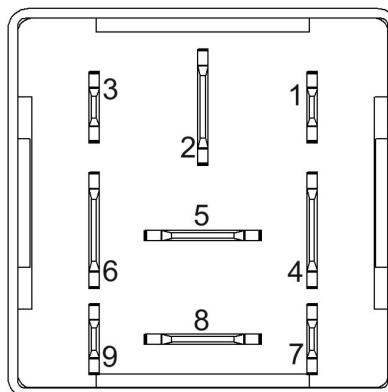

Pin assignment, bottom view

CONNECTION DIAGRAM

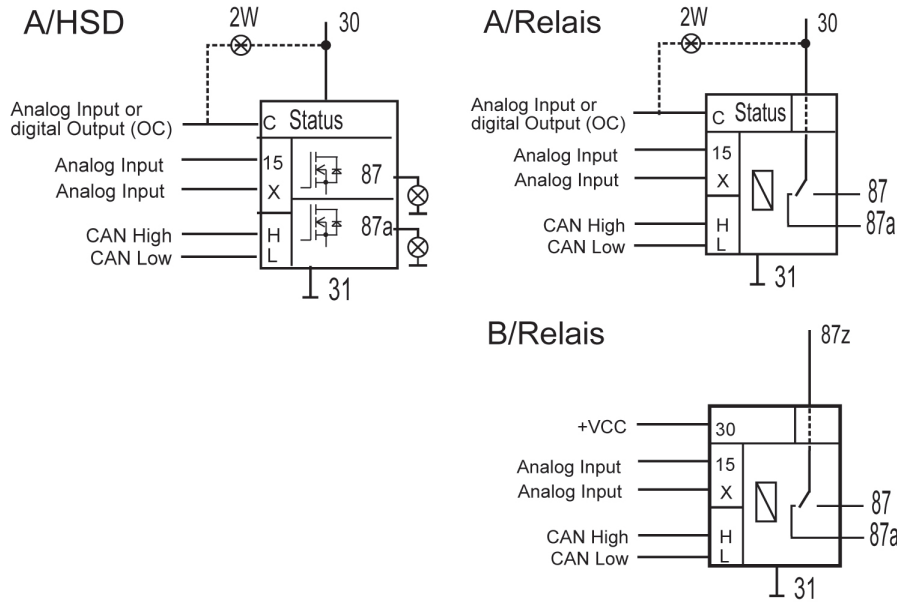

PIN - FEATURE MAP

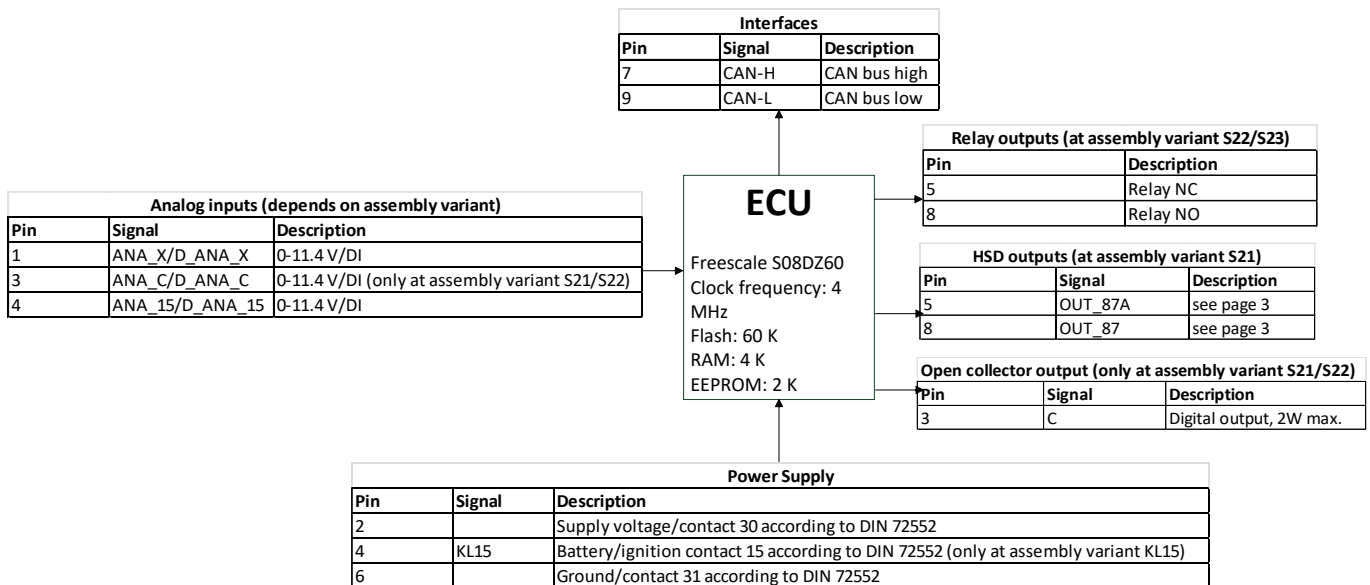

BLOCK FUNCTION DIAGRAM A

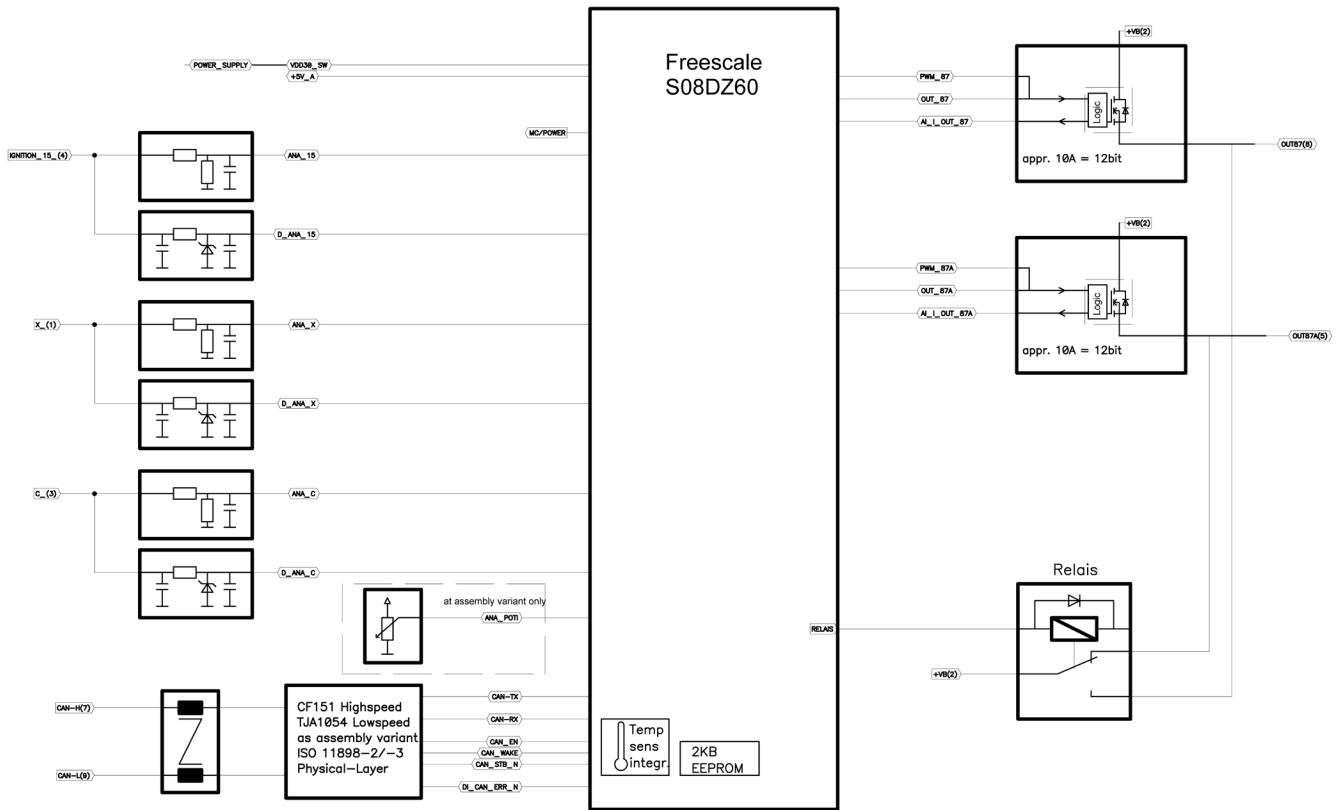

BLOCK FUNCTION DIAGRAM B

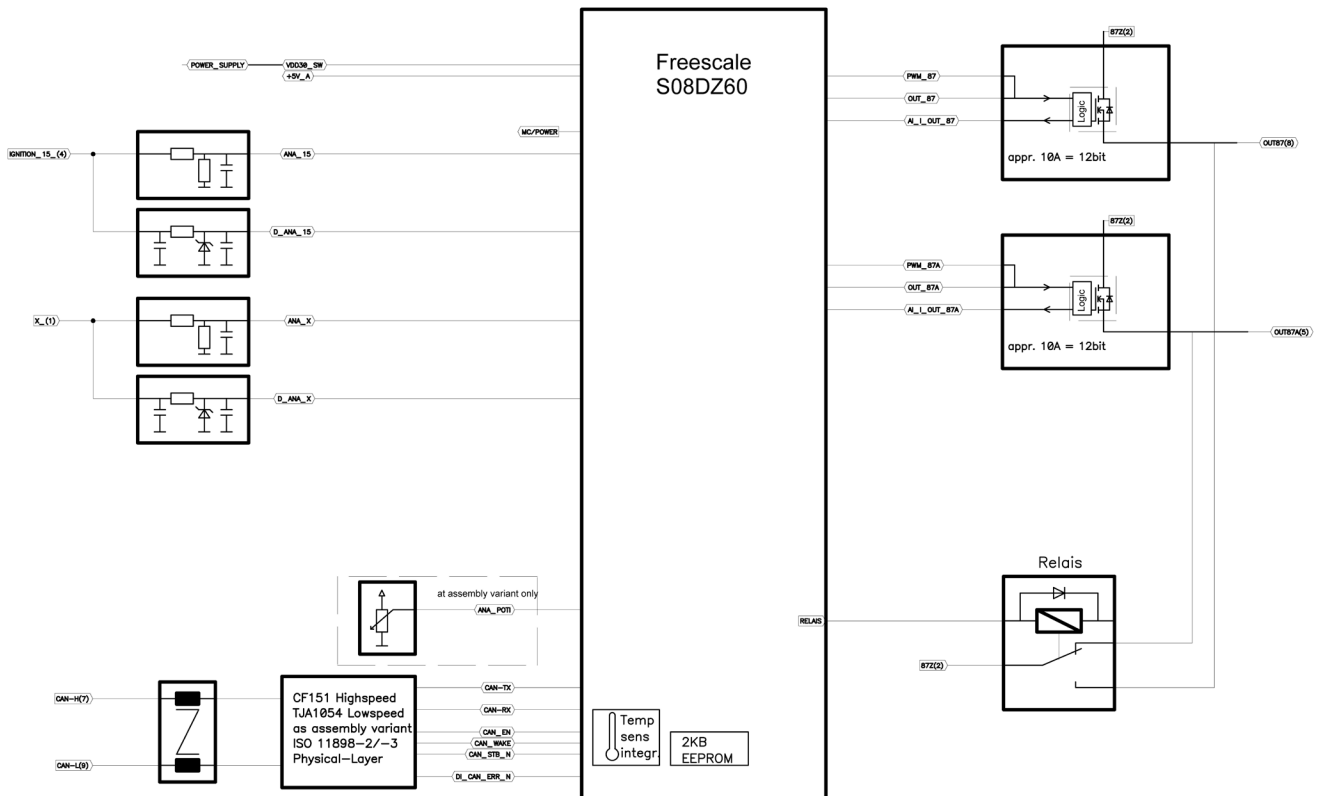

SUPPLY VOLTAGE FOR VARIANT A

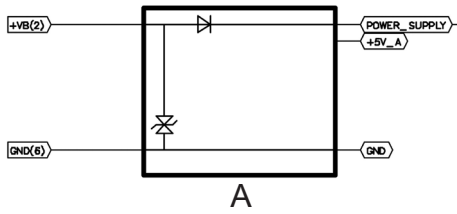

A

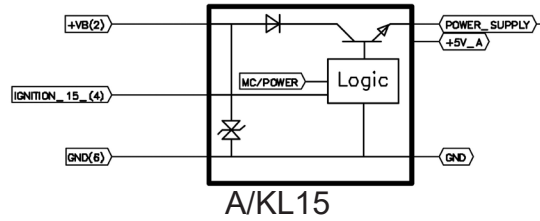

A/KL15

SUPPLY VOLTAGE FOR VARIANT B

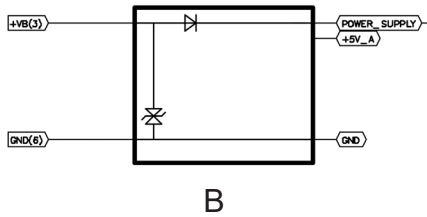

B

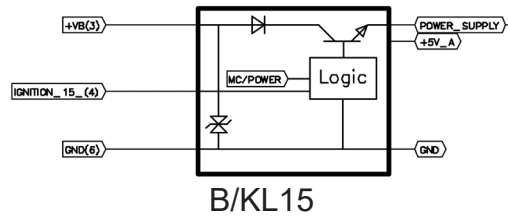

B/KL15

TECHNICAL DRAWING IN MM [INCH], TOLERANCES ACCORDING TO ISO 2768-1 V

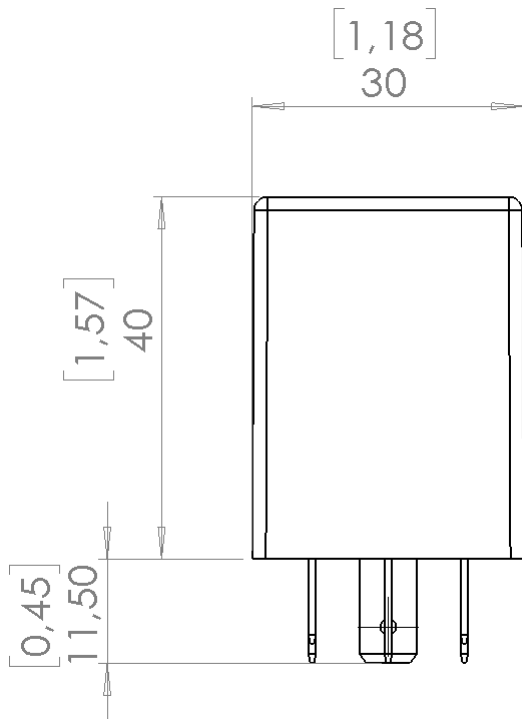

Side view

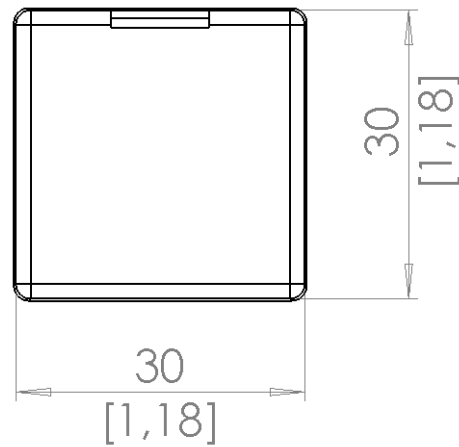

Top-down view



ASSEMBLY VARIANTS AND ORDERING INFORMATIONS WITH RELAYS OUTPUT

Order number	Supply voltage	Quiescent current 12 V	Quiescent current 24 V	Current consumption 12 V	Current consumption 24 V	Pin numbering of inputs			Pin numbering of outputs	CAN Bus	Features
						A Voltage 0 – 11.4 V	B Frequency Hz	C Digital input			
	see Page 4 or 6	Data in $\mu$ A	Data in $\mu$ A	Data in mA $\pm$ 2 mA	Data in mA $\pm$ 2 mA				D Relay output	High-Speed	
<b>1.107.110.00</b>	12 V/A	-	-	27	-	1,3,4		1,3,4	5,8	X	
<b>1.107.110.01</b>	12 V/A	-	-	27	-	3,4	1	1,3,4	5,8	X	
<b>1.107.110.03</b>	12 V/A	-	-	27	-	3,4	1	1,3,4	5,8	X	with potentiometer
<b>1.107.110.0A</b>	12 V/A	-	-	27	-	3,4	1	1,3,4	5,8	X	Pin 4: 0-33,6 V
<b>1.107.112.00</b>	12 V/B	-	-	27	-	1,4		1,4	5,8 (potential-free)	X	
<b>1.107.114.00</b>	12 V/B/ KL15	1063	-	27	-	1		1	5,8 (potential-free)	X	Pin 4 for voltage monitoring up to 11.4 V usable
<b>1.107.114.09</b>	12 V/B/ KL15	259	-	27	-	1		1	5,8 (potential-free)	X	Pin 4 for voltage monitoring up to 11.4 V usable
<b>1.107.210.00</b>	24 V/A	-	-	-	27	1,3,4		1,3,4	5,8	X	
<b>1.107.211.08</b>	24 V/A/ KL15	450	-	-	27	1	3	1,3	5,8	X	Pin 4 for voltage monitoring up to 11.4 V usable
<b>1.107.212.00</b>	24 V/B	-	-	-	27,2	1,4		1,4	5,8 (potential-free)	X	
<b>1.107.212.01</b>	24 V/B	-	-	-	26,1	4	1	1,4	5,8 (potential-free)	X	
<b>1.107.212.04</b>	24 V/B	-	-	-	37,6	1,4		1,4	5,8 (potential-free)	X	120 $\Omega$ CAN-Bus terminating resistor integrated

SCIP number: c863a8eb-b3a8-4959-ad25-b1d7bfed4e1c



ASSEMBLY VARIANTS AND ORDERING INFORMATIONS WITH HIGH-SIDE OUTPUT

Order number	Supply voltage	quies-cent curent	quies-cent curent	current consump-tion	current consump-tion	Pin numbering of inputs			Pin numbering of outputs		CAN Bus	Features
		12 V	24 V	12 V	24 V	A	B	C	E	F		
	see page 4 or 6	Data in $\mu\text{A}$ $\pm 10 \mu\text{A}$	Data in $\mu\text{A}$ $\pm 10 \mu\text{A}$	Data in mA $\pm 2 \text{ mA}$	Data in mA $\pm 2 \text{ mA}$	Voltage 0 – 11.4 V	Frequency Hz	Digital input	High-Side output	PWM $\leq 500 \text{ Hz}$	High-Speed	
<b>1.107.310.001</b>	9-32 V/A	-	-	23	24	1,3,4		1,3,4	5,8	5,8	X	
<b>1.107.310.061</b>	9-32 V/A	-	-	23	24	3,4	1,4	1,3,4	5,8	5,8	X	
<b>1.107.310.071</b>	9-32 V/A	-	-	23	24	3,4	1	1,3,4	5,8	5,8	X	Frequency input with 5 V amplitude
<b>1.107.311.001</b>	9-32 V/A/ KL15	250	400	23	24	1,3		1,3	5,8	5,8	X	PIN 4 for voltage monitoring up to 11.4 V usable
<b>1.107P.310.001</b>	9-32 V / A	-	-	23	24	1,3,4		1,3,4	5,8	5,8	X	CANopen

SCIP number: ed9d45e0-5ba3-48c7-b5a1-3b54f9b15e10

ACCESSORIES

Name	Order number
Starter-Kit µSPS CAN	1.100.110.22
Programming tool MRS Applies Studio	1.100.200.01
PCAN-USB Interface	105358
Cable sets to program	109446
Socket	1.017.002.00
Socket package watertight 40 mm	1.017.010.40
Tab receptacle 6,3 mm/1,5-2,5 mm <sup>2</sup>	103064
Tab receptacle 2,8 mm/0,5-1,0 mm <sup>2</sup>	105292



MANUFACTURER

MRS Electronic, Inc.  
 6680 Poe Avenue Suite 100  
 Dayton OH, 45414

### NOTES ON WIRING AND CABLE ROUTING

Hightside outputs may only be connected to ground.

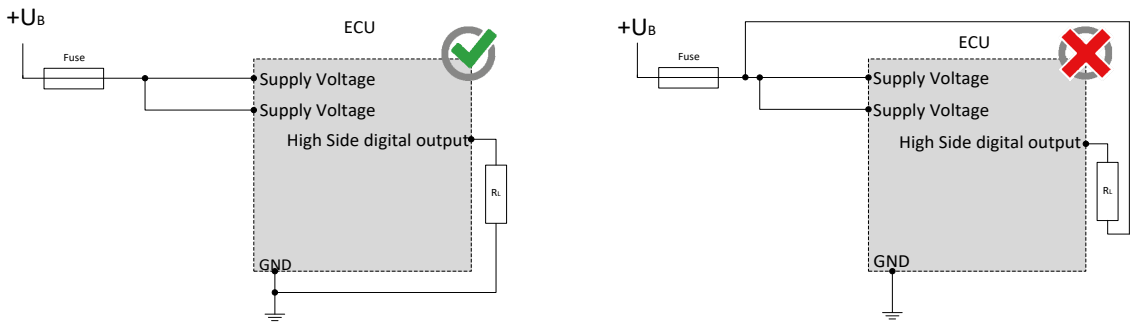

The control must be protected against overload (see performance data)

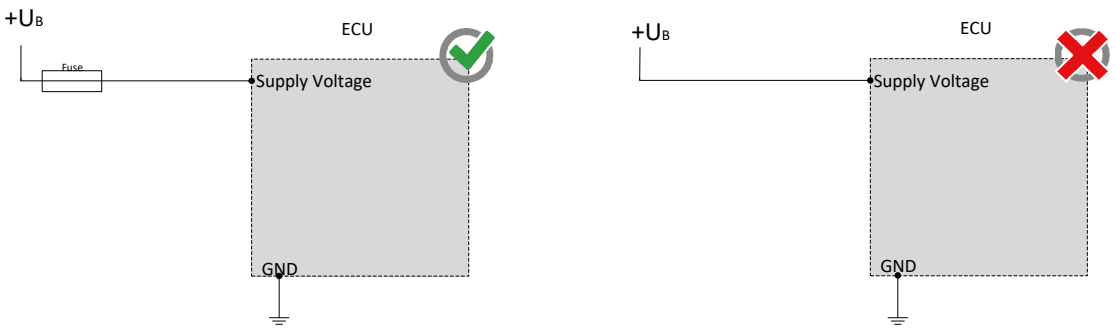

CAN bus communication is the main communication between the control unit and the vehicle. Therefore, connect the CAN bus with special care and check the correct communication with the vehicle to avoid undesired behavior.

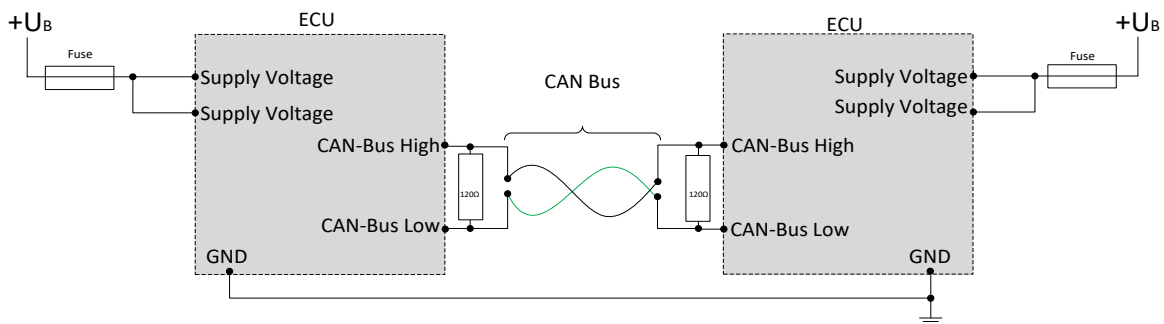

PWM outputs may not be connected with each other or bypassed.

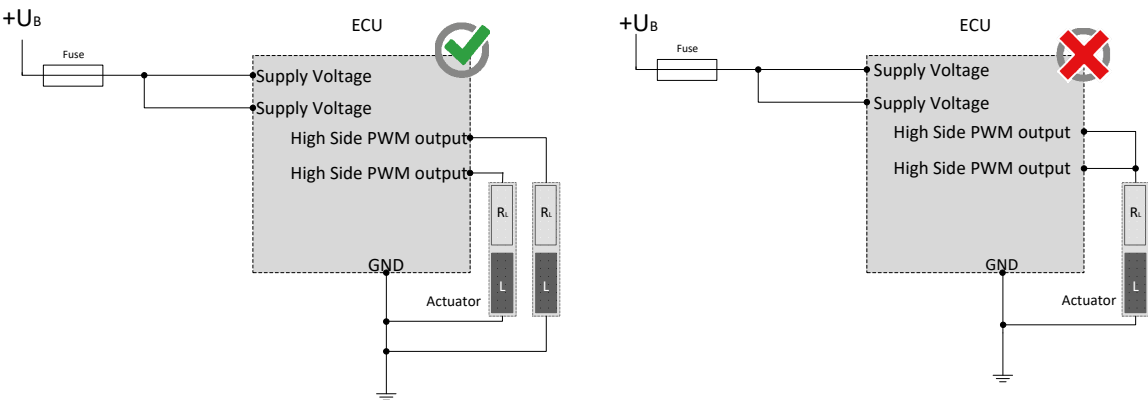

## SAFETY AND INSTALLATION INFORMATION

It is essential to read the instructions in full thoroughly before working with the device.

Please note and comply with the instructions in the operating instructions and the information in the device data sheet, see [www.mrs-electronic.com](http://www.mrs-electronic.com)

**Staff qualification:** Only staff with the appropriate qualifications may work on this device or in its proximity.

### SAFETY



**WARNING! Danger as a result of a malfunction of the entire system.**

Unforeseen reactions or malfunctions of the entire system may jeopardise the safety of people or the machine.

- Ensure that the device is equipped with the correct software and that the wiring and settings on the hardware are appropriate.



**WARNING! Danger as a result of unprotected moving components.**

Unforeseen dangers may occur from the entire system when putting the device into operation and maintaining it.

- Switch the entire system off before carrying out any work and prevent it from unintentionally switching back on.
- Before putting the device into operation, ensure that the entire system and parts of the system are safe.
- The device should never be connected or separated under load or voltage.



**CAUTION! Risk of burns from the housing.**

The temperature of the device housing may be elevated.

- Do not touch the housing and let all system components cool before working on the system.

### PROPER USE

The device is used to control or switch one or more electrical systems or sub-systems in motor vehicles and machines and may only be used for this purpose. The device may only be used in an industrial setting.



**WARNING! Danger caused by incorrect use.**

The device is only intended for use in motor vehicles and machines.

- Use in safety-related system parts for personal protection is not permitted.
- Do not use the device in areas where there is a risk of explosion.

**Correct use:**

- operating the device within the operating areas specified and approved in the associated data sheet.
- strict compliance with these instructions and no other actions which may jeopardise the safety of individuals or the functionality of the device.

**Obligations of the manufacturer of entire systems**

It is necessary to ensure that only functional devices are used. If devices fail or malfunction, they must be replaced immediately.

System developments, installation and the putting into operation of electrical systems may only be carried out by trained and experienced staff who are sufficiently familiar with the handling of the components used and the entire system.

It is necessary to ensure that the wiring and programming of the device does not lead to safety-related malfunctions of the entire system in the event of a failure or a malfunction. System behaviour of this type can lead to a danger to life or high levels of material damage.

The manufacturer of the entire system is responsible for the correct connection of the entire periphery (e.g. cable cross sections, correct selection/connection of sensors/actuators).

Opening the device, making changes to the device and carrying out repairs are all prohibited. Changes or repairs made to the cabling can lead to dangerous malfunctions. Repairs may only be carried out by MRS.

**Installation**

The installation location must be selected so the device is exposed to as low a mechanical and thermal load as possible. The device may not be exposed to any chemical loads.

Install the device in such a manner that the plugs point downwards. This means condensation can flow off the device. Single seals on the cables/leads must be used to ensure that no water gets into the device.

**Putting into operation**

The device may only be put into operation by qualified staff. This may only occur when the status of the entire system corresponds to the applicable guidelines and regulations.

### FAULT CORRECTION AND MAINTENANCE



**NOTE The device is maintenance-free and may not be opened.**

- If the device has damage to the housing, latches, seals or flat plugs, it must be taken out of operation.

Fault correction and cleaning work may only be carried out with the power turned off. Remove the device to correct faults and to clean it.

Check the integrity of the housing and all flat plugs, connections and pins for mechanical damage, damage caused by overheating, insulation damage and corrosion. In the event of faulty switching, check the software, switches and settings.

Do not clean the device with high pressure cleaners or steam jets. Do not use aggressive solvents or abrasive substances.