

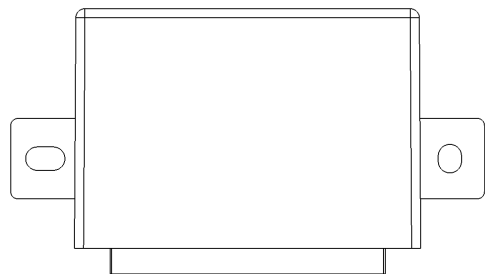

DESCRIPTION

The Universal Gateway 5x Can by MRS allows data exchange between CAN-Bus systems. The open and flexible design, tailored to automotive applications, allows a quick adaptation to customer-specific requirements even for small quantities.



mounting direction

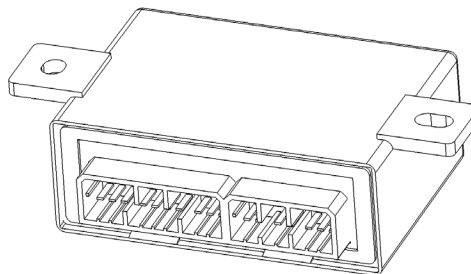

view of plug

TECHNICAL DATA

Housing	Plastic PA66GF30
Connector	.070 Multilock 18P Housing .070 Multilock 12P Housing
Weight	110 g
Temperature range (ISO 16750-4 compliant)	-40 °C to +85 °C
Environmental Protection	IP 54
Current consumption	33 mA at 12V; 50 mA at 24 V
Over-current Protection	1 A + load
Total Inputs and outputs	9 (5 inputs, 4 outputs)
Inputs	Configurable as: 1 analog input (0...11.4 V) 4 digital inputs Frequency inputs (depending on assembly options)
Outputs	Configurable as: 4 digital outputs
Operating voltage	9-32 V 12 V (Code B) and 24 V (Code E) ISO 16750-2 compliant at -40 °C:10.5-32 V 12 V (Code D) and 24 V (Code F) ISO 16750-2 compliant
Starting voltage	8 V
Overvoltage protection	≥ 33V
Quiescent current	150 µA at 12 V; 3.3 mA at 24 V
Reverse polarity protection	Yes
CAN interfaces	CAN interface 2.0 A/B, ISO 11898-2

REGULATORY APPROVALS AND TESTING

E1 approval	ECE R10 05 7258
Elektrical tests	Acc. to ISO 16750: Reverse polarity Short circuit protection (except RS232 interface) Pin interruption Connector interruption Storage test at Tmin Storage test at Tmax Acc. to ISO 7637 - 2: Puls 1, 2a, 2b, 3a, 3b, 4

SOFTWARE/PROGRAMMING

Programming System

MRS Developers Studio
MRS Developers Studio with built-in functions library, similar to programming with FUP. Custom software blocks can be integrated into "C-code". Program memory is sufficient for about 300 basic logic components.



INPUT FEATURES - SUMMARY

Pin 1.12	Programmable as analog or digital input		Pin 2.14; 2.15; 2.16; 2.17	Programmable as digital input	
	Resolution	12 Bit		Resolution	12 Bit
	Accuracy	± 1 % full scale		Accuracy	± 1 % full scale
Voltage input 0...11.4 V (see A)	Input resistance	22.6 kΩ	Digital input (see B)	Input resistance	21.1 kΩ
	Input frequency	fc ¹ = 68 Hz		Input frequency	7 V
	Accuracy	± 3 %		Accuracy	3 V
Digital input Positive (see A)	Input resistance	22.6 kΩ	Frequency input (see B)	Input resistance	21.1 kΩ
	Input frequency	fc ¹ = 68 Hz		Input frequency	fc ¹ = 10 kHz
	Turn-on threshold	6.5 V		Accuracy	≤ 3% up to 20 kHz ² / 26 kHz ³
	Turn-off threshold	5.2 V		Turn-on threshold	7 V
				Turn-off threshold	5 V

¹ cutoff frequency (-3 dB)

²sine wave, 10 V_{pp} 5 V offset, using "frequency read" function

³square wave, 10 V_{pp} 5 V offset, using "frequency read" function

OUTPUT FEATURES - SUMMARY

Pin 2.3, 2.9, 2.10, 2.11	Protective circuit for inductive loads	Integrated
	Wire fault diagnostics	Possible via current sense
	Short circuit diagnostics	Possible via current sense
Digital, positive switching (high side; see C)	Switching voltage	9-32 V
	Switching current	0.02 - 2.5 A
Short circuit resistance against GND and VS	Switching-off is controlled by high side driver for each output channel	



PIN ASSIGNMENT POWER SUPPLY AND INTERFACES

Pin	Description	Pin	Description
1.1	CAN bus 0 high	2.1	CAN bus 2 high
1.2	CAN bus 0 low	2.2	CAN bus 2 low
1.3	RS 485 - A	2.4	LIN bus (depending on assembly options)
1.4	Ground	2.6	CAN bus 4 high
1.5	Operating voltage	2.7	CAN bus 4 low
1.6	CAN bus 1 high	2.12	CAN bus 3 high
1.7	CAN bus 1 low	2.13	CAN bus 3 low
1.8	RS 485 - B		
1.9	RS232 - TX		
1.10	RS232 - RX		
1.11	Battery/ignition/analog-digital input		

PIN ASSIGNMENT INPUTS AND OUTPUTS

Pin	Signal	Description	Pin	Signal	Description
1.12	AI_ANA0	Analog input 0-11.4 V or digital input	2.14	DI_INT_1	Frequency input 1
2.3	DO_2	Digital output 2 with current sense via AI_I_DO_2	2.15	DI_INT_2	Frequency input 2
2.9	DO_1	Digital output 1 with current sense via AI_I_DO_1	2.16	DI_INT_3	Frequency input 3
2.10	DO_4	Digital output 4 with current sense via AI_I_DO_4	2.17	DI_INT_4	Frequency input 4
2.11	DO_3	Digital output 3 with current sense via AI_I_DO_3			

UNUSED PINS

Pin	Pin	Pin
2.5	2.8	2.18

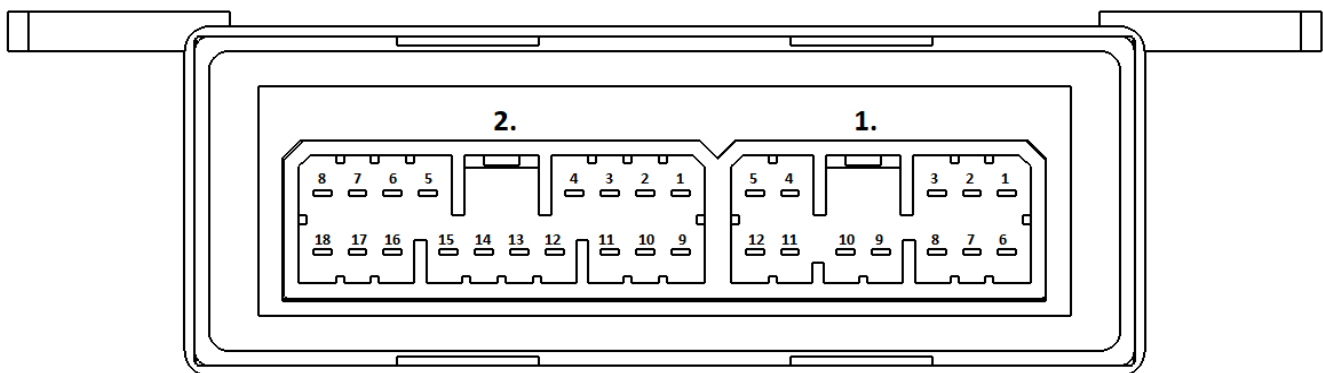

view of plug



PIN - FEATURE MAP

Interfaces	
Pin	Description
1.1	CAN - Bus 0 high
1.2	CAN - Bus 0 low
1.3	RS 485 - A
1.6	CAN - Bus 1 high
1.7	CAN - Bus 1 low
1.8	RS 485 - B
1.9	RS232 - TX
1.10	RS232 - RX
2.1	CAN - Bus 2 high
2.2	CAN - Bus 2 low
2.4	LIN - Bus
2.6	CAN - Bus 4 high
2.7	CAN - Bus 4 low
2.12	CAN - Bus 3 high

Analog inputs (depends on assembly variant)		
Pin	Signal	Description
1.12	AI_ANA0	0-11.4 V
2.14	DI_INT_1	frequency input 1 (assembly variant)
2.15	DI_INT_2	frequency input 2 (assembly variant)
2.16	DI_INT_3	frequency input 3 (assembly variant)
2.17	DI_INT_4	frequency input 4 (assembly variant)

ECU
 S9S12XEQ384
 Clock frequency: 4 MHz
 Flash: 384 KB
 RAM: 24 KB
 EEPROM: 4 KB

HSD outputs		
Pin	Signal	Description
2.3	DO_2	digital output with current sense
2.9	DO_1	digital output with current sense
2.10	DO_4	digital output with current sense
2.11	DO_3	digital output with current sense

Power Supply		
Pin	Signal	Description
1.4		Ground / contact 31 according to DIN 72552
1.5		Supply voltage/ contact 30 according to DIN 72552
1.11	AI_KL15	Ignition/ contact 15 according to DIN 72552

BLOCK FUNCTION DIAGRAM

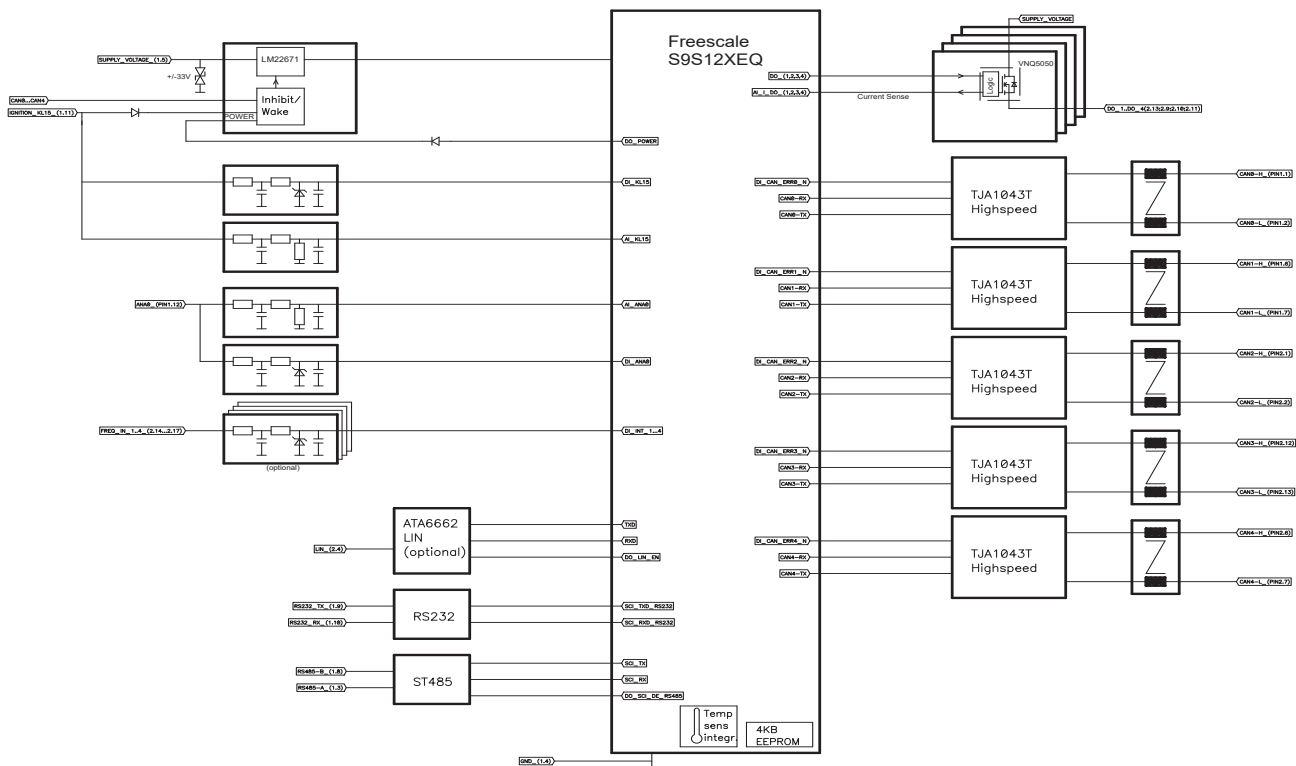



TECHNICAL DRAWING IN MM [IN INCH]

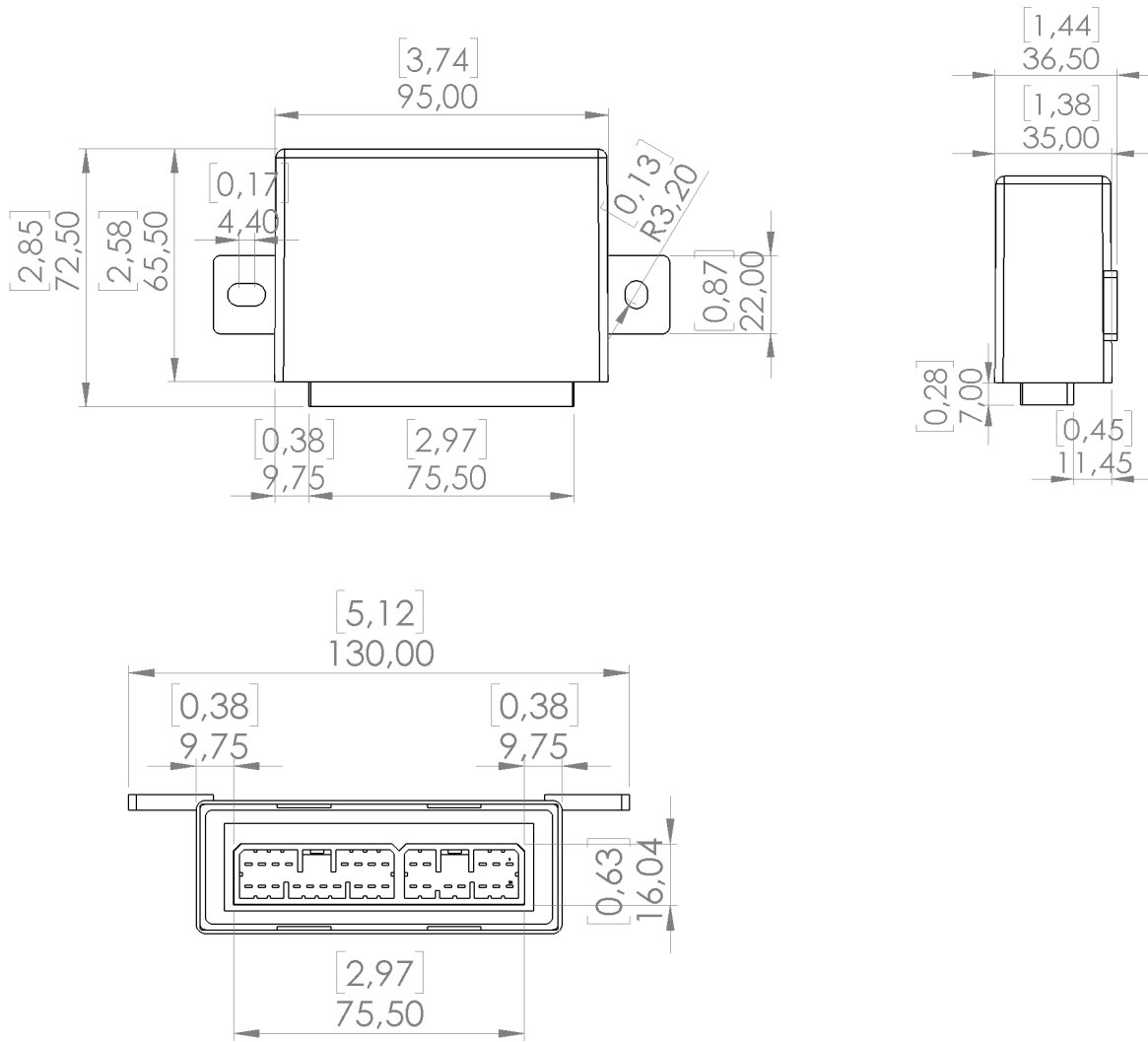



ASSEMBLY OPTIONS AND ORDER INFORMATION

Assembly variant	Pin number inputs		Pin number outputs	CAN Bus	Serial Interfaces			Wake-up possibilities	Notes	
	A voltage or digital 0 – 11.4 V	B frequency Hz			RS485	RS232	LIN		with side-flaps	without side-flaps
1.057.300.0000	1.12		2.3, 2.9; 2.10, 2.11	X	X	X			X	
1.057.300.0203	1.12	2.14, 2.15, 2.16, 2.17	2.3, 2.9, 2.10, 2.11	X	X	X	CAN, LIN, KL15	X		
1.057.300.0303	1.12	2.14, 2.15, 2.16, 2.17	2.3, 2.9; 2.10, 2.11	X	X	X	KL15	X		



ACCESSORIES

Description	Order number
Programming tool MRS Developers Studio	1.100.100.09
Cable set to program Universal Gateway 5 x CAN	109260
Connector package Universal Gateway 5 x CAN	109203
PCAN-USB Interface	105358



MANUFACTURER

MRS Electronic, Inc
2149 Winners Circle
Dayton, OH 45404

NOTES ON WIRING AND CABLE ROUTING

Hightside outputs may only be switched to ground.

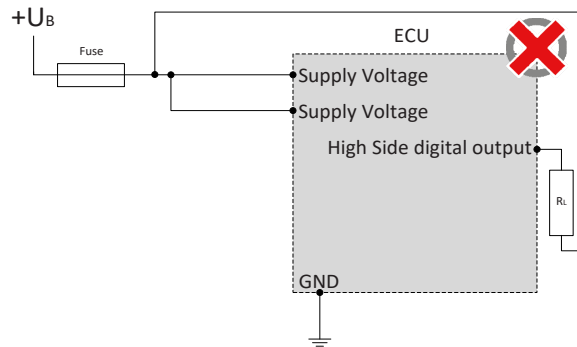
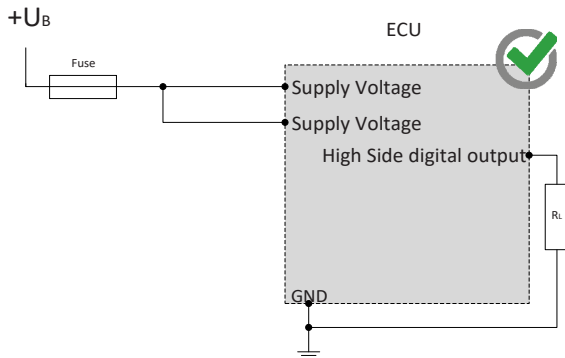
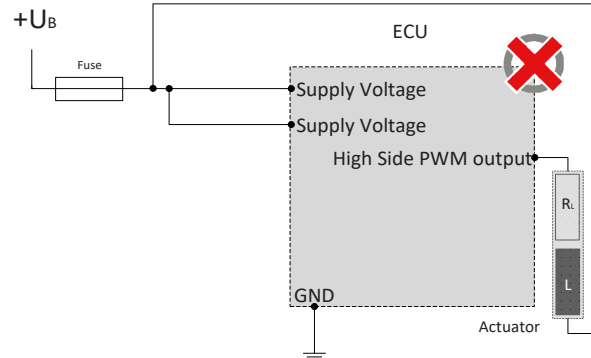
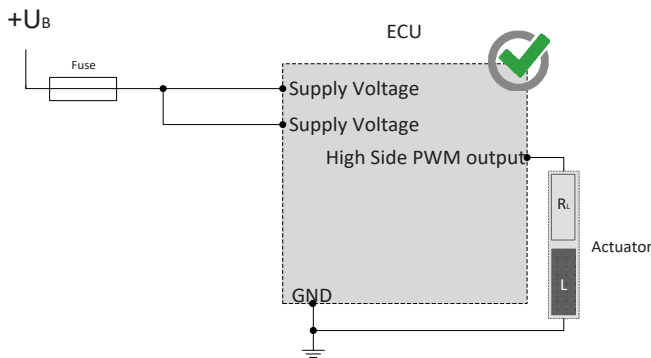

The sensor supplies can be "lifted" through an external circuitry, for example the creation of higher voltage, as they only work as a voltage source but not as voltage drain. The lift of a voltage source may lead to unforeseen malfunctions and damages of the control unit in case of permanent operation.

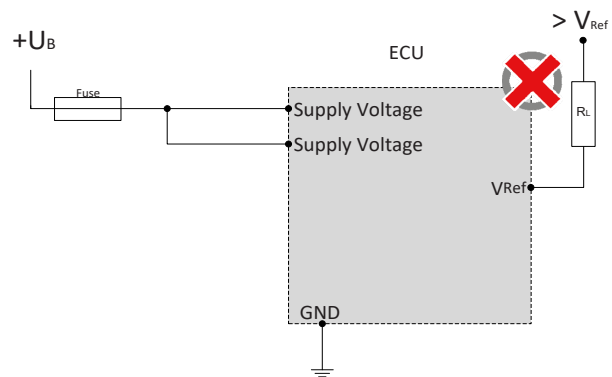
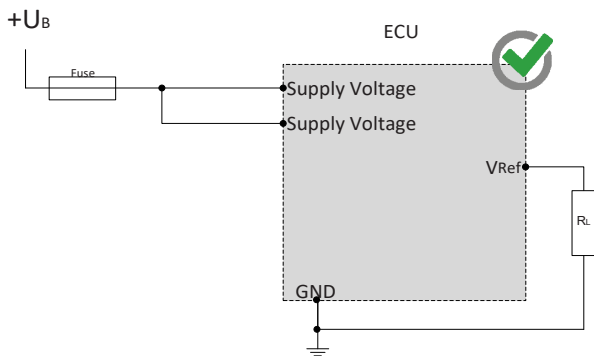

CAN bus communication is the main communication between the control unit and the vehicle. Therefore, connect the CAN bus with special care and check the correct communication with the vehicle to avoid undesired behavior.

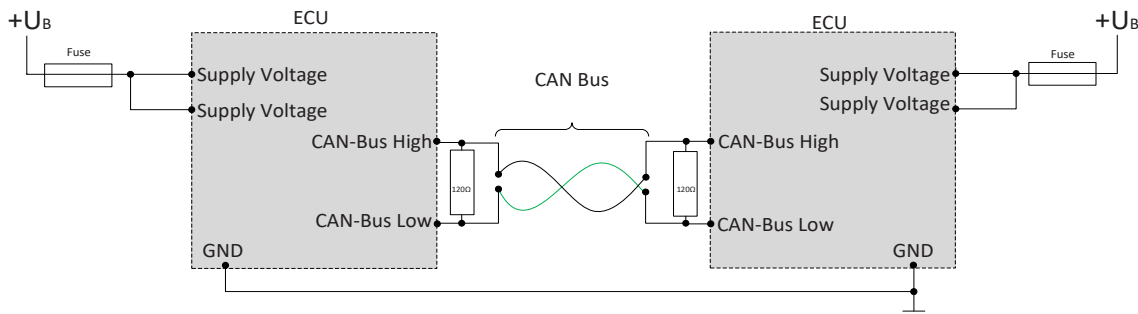

SAFETY AND INSTALLATION INFORMATION

It is essential to read the instructions in full thoroughly before working with the device.

Please note and comply with the instructions in the operating instructions and the information in the device data sheet, see www.mrs-electronic.de

Staff qualification: Only staff with the appropriate qualifications may work on this device or in its proximity.

SAFETY

⚠ WARNING! Danger as a result of a malfunction of the entire system.
Unforeseen reactions or malfunctions of the entire system may jeopardise the safety of people or the machine.

- Ensure that the device is equipped with the correct software and that the wiring and settings on the hardware are appropriate.

⚠ WARNING! Danger as a result of unprotected moving components.
Unforeseen dangers may occur from the entire system when putting the device into operation and maintaining it.

- Switch the entire system off before carrying out any work and prevent it from unintentionally switching back on.
- Before putting the device into operation, ensure that the entire system and parts of the system are safe.
- The device should never be connected or separated under load or voltage.

⚠ CAUTION! Risk of burns from the housing.
The temperature of the device housing may be elevated.

- Do not touch the housing and let all system components cool before working on the system.

PROPER USE

The device is used to control or switch one or more electrical systems or sub-systems in motor vehicles and machines and may only be used for this purpose. The device may only be used in an industrial setting.

⚠ WARNING! Danger caused by incorrect use.
The device is only intended for use in motor vehicles and machines.

- Use in safety-related system parts for personal protection is not permitted.
- Do not use the device in areas where there is a risk of explosion.

Correct use:

- operating the device within the operating areas specified and approved in the associated data sheet.
- strict compliance with these instructions and no other actions which may jeopardise the safety of individuals or the functionality of the device.

Obligations of the manufacturer of entire systems

It is necessary to ensure that only functional devices are used. If devices fail or malfunction, they must be replaced immediately.

System developments, installation and the putting into operation of electrical systems may only be carried out by trained and experienced staff who are sufficiently familiar with the handling of the components used and the entire system.

It is necessary to ensure that the wiring and programming of the device does not lead to safety-related malfunctions of the entire system in the event of a failure or a malfunction. System behaviour of this type can lead to a danger to life or high levels of material damage.

The manufacturer of the entire system is responsible for the correct connection of the entire periphery (e.g. cable cross sections, correct selection/connection of sensors/actuators).

Opening the device, making changes to the device and carrying out repairs are all prohibited. Changes or repairs made to the cabling can lead to dangerous malfunctions. Repairs may only be carried out by MRS.

Installation

The installation location must be selected so the device is exposed to as low a mechanical and thermal load as possible. The device may not be exposed to any chemical loads.

Install the device in such a manner that the plugs point downwards. This means condensation can flow off the device. Single seals on the cables/leads must be used to ensure that no water gets into the device.

Putting into operation

The device may only be put into operation by qualified staff. This may only occur when the status of the entire system corresponds to the applicable guidelines and regulations.

FAULT CORRECTION AND MAINTENANCE

ⓘ NOTE The device is maintenance-free and may not be opened.

- If the device has damage to the housing, latches, seals or flat plugs, it must be taken out of operation.

Fault correction and cleaning work may only be carried out with the power turned off. Remove the device to correct faults and to clean it.

Check the integrity of the housing and all flat plugs, connections and pins for mechanical damage, damage caused by overheating, insulation damage and corrosion. In the event of faulty switching, check the software, switches and settings.

Do not clean the device with high pressure cleaners or steam jets. Do not use aggressive solvents or abrasive substances.