

mounting direction

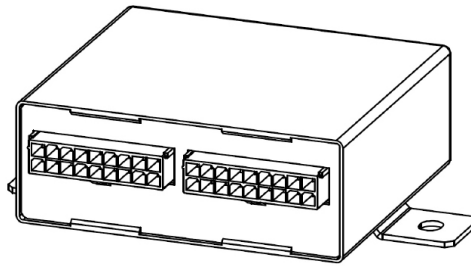

view of plug

DESCRIPTION

The CAN Relay Box is the appropriate product when you want to determine potential-free, switching output signals that must be connected. You can set the signal potential yourself and individually for your application. The 12 potential-free relays can be activated using CAN messages. The module can be integrated into your network as a separate PLC or as a simple I/O module.

TECHNICAL DATA

Housing	Plastic PA66GF30
Connector	3 x 18 pol. Molex Mini Fit Jr.
Weight	200 g incl. mounting clip
Temperature range (ISO 16750-4 compliant)	-40 °C to +85 °C (at +85 °C not full load)
Environmental Protection	IP 53
Current consumption	30 mA (12 V); 35 mA (24 V)
External protection	1 A + load
Total Inputs and outputs	25 (13 analog inputs, 12 potential-free Relays)
Inputs	Configurable as: Analog (0...11.4 V)
Outputs	Configurable as: potential-free Relays
Operating voltage	9 V to 32 V 12 V (Code C) and 24 V (Code E) acc. to ISO 16750-2
Starting voltage	8 V
Overvoltage protection	≥ 33 V
Undervoltage cut-off	≤ 8 V
Quiescent current	240 µA (12 V); 450 µA (24 V)
Reverse polarity protection	Yes
CAN interfaces	CAN interface 2.0 A/B ISO 11898-2:2016

REGULATORY APPROVALS AND TESTING

E1 approval	05 9051
EMC measurements	DIN EN 55025 acc. to MBN 10284-4 2004-04 paragraph 8 imd CISPR 25 2008-03 paragraph 6.4
Electrical tests	Acc. to ISO 16750-2:2012: <ul style="list-style-type: none"> • Reverse Polarity • Short circuit protection • Pin/connector Interruption • Long-term overvoltage protection at $T_{+65\text{ °C}}$ • Superimposed alternating voltage • Slow decrease and increase of supply voltage • Momentary drop in supply voltage • Reset behavior at voltage drop
	Acc. to ISO 16750-4:2010: <ul style="list-style-type: none"> • Storage test at T_{min} and T_{max} • Operation test at T_{min} und T_{max} • Temperature steps • Moist heat
	Acc. to ISO 7637-2:2004: Pulse 1, 2a, 2b, 3a, 3b and 4
	Acc. to ISO 10605:2008: to ± 15 kV ESD handling test (Class C) to ± 15 kV ESD powered up test (Class A)

SOFTWARE/PROGRAMMING

Programming System

MRS Developers Studio

MRS Developers Studio with built-in functions library, similar to programming with FUP. Custom software blocks can be integrated into "C-code". Program memory is sufficient for about 300 basic logic components.

INPUT FEATURES - SUMMARY

Pin X103.2;	Programmable as	
X103.3; X103.4;	analog or digital ² input	
X103.5; X103.6;	Resolution	12 Bit
X103.7; X103.8;	Accuracy	±1 % full scale
X103.11, X103.12;		
X103.13; X103.14;		
X103.15; X103.16;		
X103.17		

Voltage input	Input resistance	22.68 kΩ
0...11.4 V	Input frequency ¹	f _g = 30 Hz
	Accuracy	± 3 %

¹ cutoff frequency (-3 dB)

² Programmable as digital input e.g. with comparator (see Developers Studio) up to the maximum operating voltage see P.1

OUTPUT FEATURES - SUMMARY

Pin X102.1;
X102.4; X102.7;
X102.11; X102.14;
X102.17; X101.1;
X101.4; X101.7;
X101.11; X101.14;
X101.17

NO Relays

Switching voltage	12 V + 24 V
Switching current	4 A at +85 °C 8 A at +23 °C (tested with 28 V, resistive load)

Pin X102.10;
X102.12; X102.13;
X102.15; X102.16;
X102.18; X101.10;
X101.12; X101.13;
X101.15; X101.16;
X101.18;

NC Relays

Switching voltage	12 V + 24 V
Switching current	4 A at +85 °C 8 A at +23 °C (tested with 28 V, resistive load)

PIN ASSIGNMENT POWER SUPPLY AND INTERFACES

Pin	Description	Pin	Description
X103.1	Ground	X103.10	Contact 30 / Supply voltage
X103.2	Contact 15 / ignition	X103.18	CAN bus high
X103.9	CAN bus low		



PIN ASSIGNMENT INPUTS AND OUTPUTS

Pin	Signal	Description	Pin	Signal	Description
X103.3	AI_02	Analog input 2 0-11.4 V	X101.1	DO_REL07	Normally open contact 07 NO
X103.4	AI_04	Analog input 4 0-11.4 V	X101.2		Changeover contact 07 COM
X103.5	AI_06	Analog input 6 0-11.4 V	X101.3		Changeover contact 08 COM
X103.6	AI_08	Analog input 8 0-11.4 V	X101.4	DO_REL09	Normally open contact 09 NO
X103.7	AI_10	Analog input 10 0-11.4 V	X101.5		Changeover contact 09 COM
X103.8	AI_12	Analog input 12 0-11.4 V	X101.6		Changeover contact 10 COM
X103.11	AI_01	Analog input 1 0-11.4 V	X101.7	DO_REL11	Normally open contact 11 NO
X103.12	AI_03	Analog input 3 0-11.4 V	X101.8		Changeover contact 11 COM
X103.13	AI_05	Analog input 5 0-11.4 V	X101.9		Changeover contact 12 COM
X103.14	AI_07	Analog input 7 0-11.4 V	X101.10	DO_REL07	Normally closed contact 07 NC
X103.15	AI_09	Analog input 9 0-11.4 V	X101.11	DO_REL08	Normally open contact 08 NO
X103.16	AI_11	Analog input 11 0-11.4 V	X101.12	DO_REL08	Normally closed contact 08 NC
X103.17	AI_13	Analog input 13 0-11.4 V	X101.13	DO_REL09	Normally closed contact 09 NC
			X101.14	DO_REL10	Normally open contact 10 NO
			X101.15	DO_REL10	Normally closed contact 10 NC
			X101.16	DO_REL11	Normally closed contact 11 NC
			X101.17	DO_REL12	Normally open contact 12 NO
			X101.18	DO_REL12	Normally closed contact 12 NC
Pin	Signal	Description			
X102.1	DO_REL01	Normally open contact 01 NO			
X102.2		Changeover contact 01 COM			
X102.3		Changeover contact 02 COM			
X102.4	DO_REL03	Normally open contact 03 NO			
X102.5		Changeover contact 03 COM			
X102.6		Changeover contact 04 COM			
X102.7	DO_REL05	Normally open contact 05 NO			
X102.8		Changeover contact 05 COM			
X102.9		Changeover contact 06 COM			
X102.10	DO_REL01	Normally closed contact 01 NC			
X102.11	DO_REL02	Normally open contact 02 NO			
X102.12	DO_REL02	Normally closed contact 02 NC			
X102.13	DO_REL03	Normally closed contact 03 NC			
X102.14	DO_REL04	Normally open contact 04 NO			
X102.15	DO_REL04	Normally closed contact 04 NC			
X102.16	DO_REL05	Normally closed contact 05 NC			
X102.17	DO_REL06	Normally open contact 06 NO			
X102.18	DO_REL06	Normally closed contact 06 NC			

PIN ASSIGNMENT

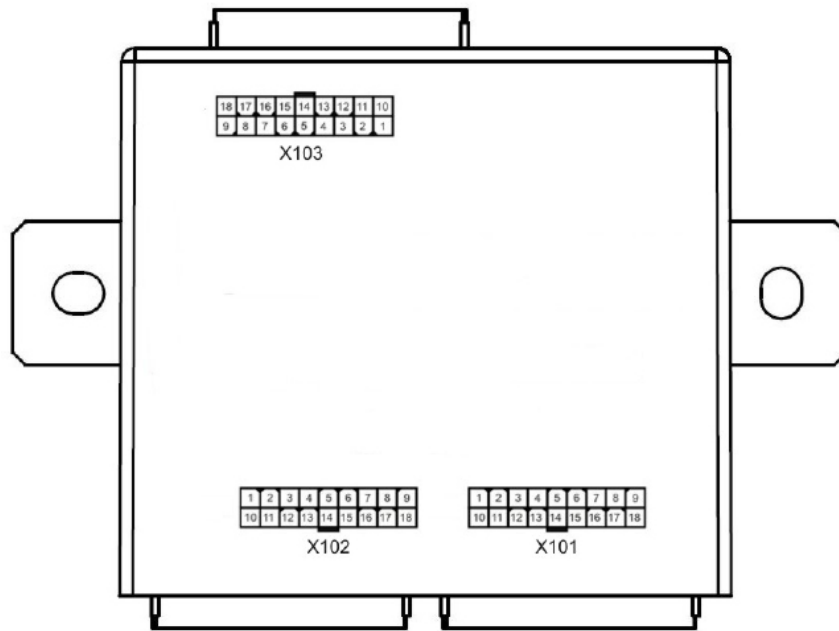

Front view

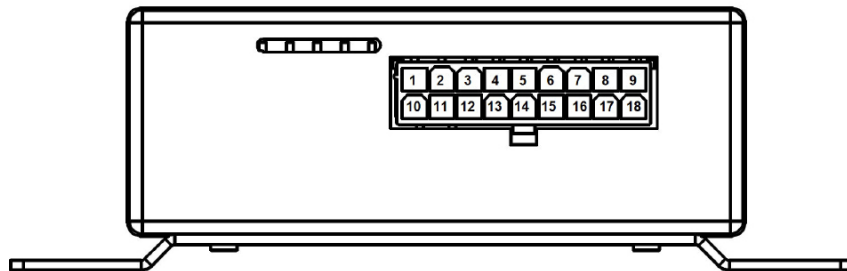

View of plug X103

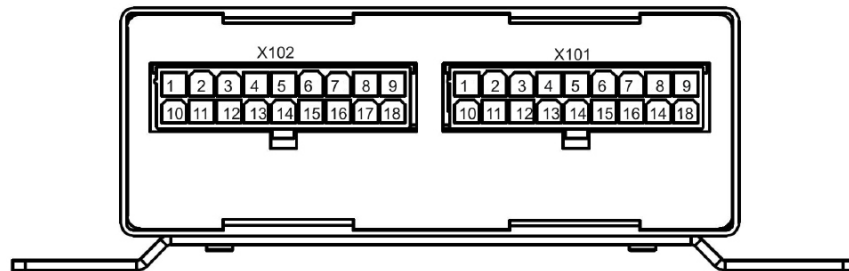

View of plug X102 and X101

PIN FEATURE MAP

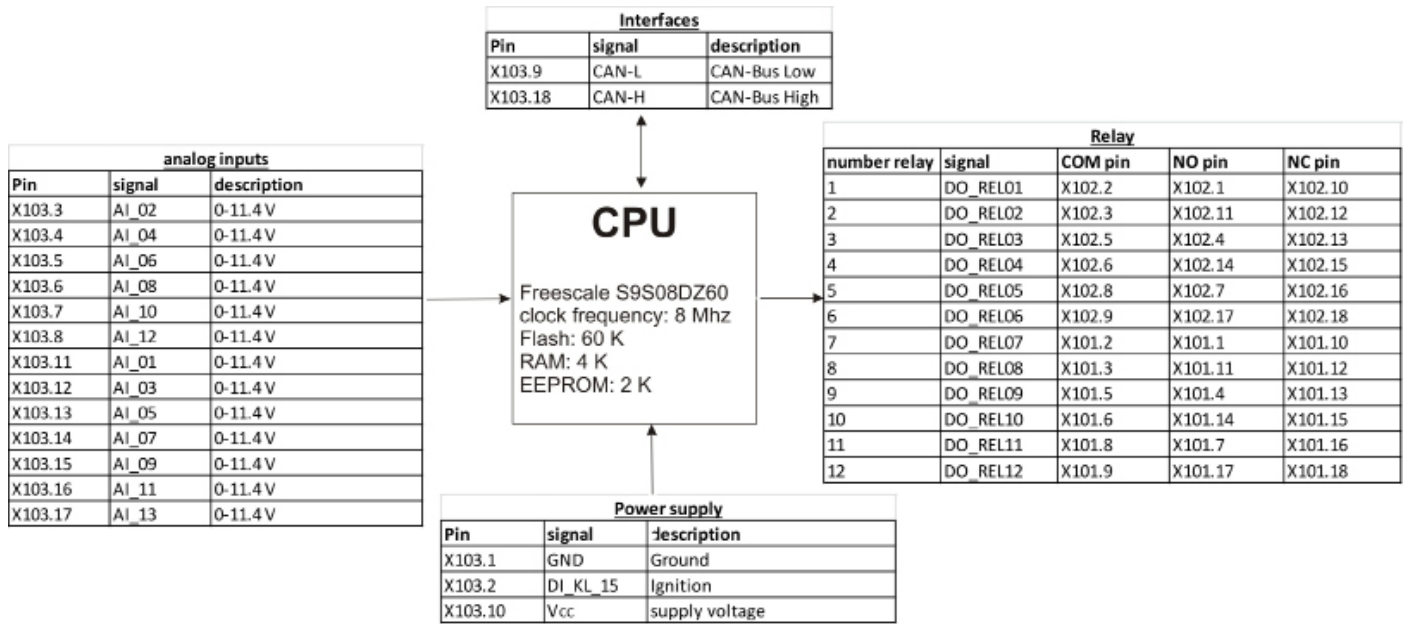

BLOCK FUNCTION DIAGRAM

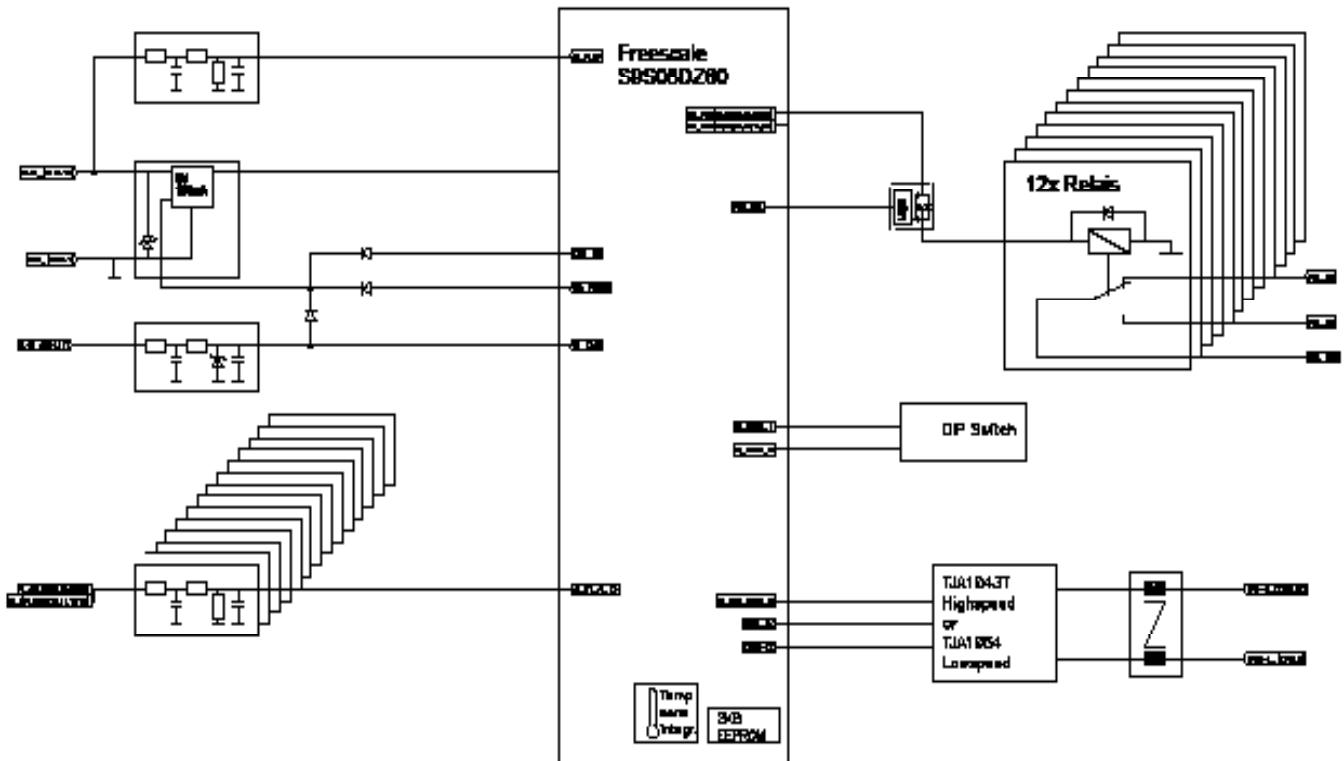

TECHNICAL DRAWING IN MM [INCH]

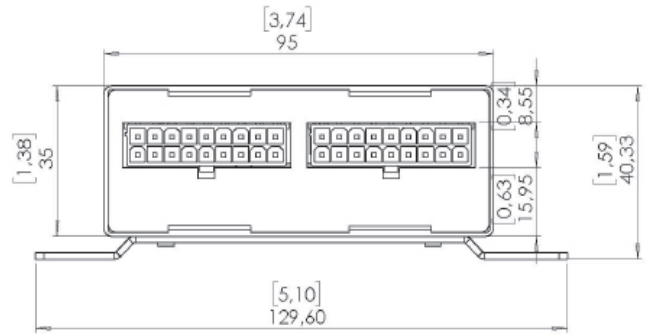
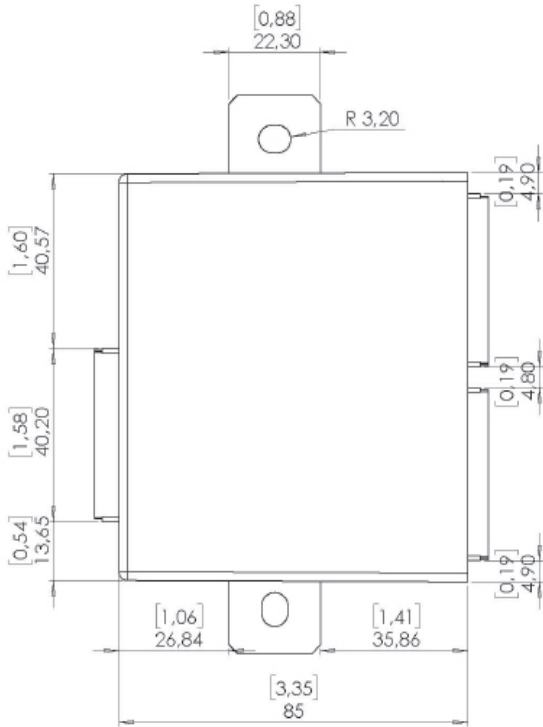



ASSEMBLY OPTIONS AND ORDER INFORMATION

	Inputs	Relay COM	Outputs			CAN Bus	
			Relais NO	Relais NC	High-Speed	Low-Speed	
	Voltage 0 – 11.4 V						
1.047.300.00	X103.2; X103.3; X103.4; X103.5; X103.6; X103.7; X103.8; X103.11, X103.12; X103.13; X103.14; X103.15; X103.16; X103.17	X102.2; X102.3; X102.5; X102.6; X102.8; X102.9; X101.2; X101.3; X101.5; X101.6; X101.8; X101.9	X102.1; X102.4; X102.7; X102.11; X102.14; X102.17; X101.1; X101.4; X101.7; X101.11; X101.14; X101.17	X102.10; X102.12; X102.13; X102.15; X102.16; X102.18; X101.10; X101.12; X101.13; X101.15; X101.16; X101.18	X		
1.047.310.00	X103.2; X103.3; X103.4; X103.5; X103.6; X103.7; X103.8; X103.11, X103.12; X103.13; X103.14; X103.15; X103.16; X103.17	X102.2; X102.3; X102.5; X102.6; X102.8; X102.9; X101.2; X101.3; X101.5; X101.6; X101.8; X101.9	X102.1; X102.4; X102.7; X102.11; X102.14; X102.17; X101.1; X101.4; X101.7; X101.11; X101.14; X101.17	X102.10; X102.12; X102.13; X102.15; X102.16; X102.18; X101.10; X101.12; X101.13; X101.15; X101.16; X101.18		X	
1.047P300.00	X103.2; X103.3; X103.4; X103.5; X103.6; X103.7; X103.8; X103.11, X103.12; X103.13; X103.14; X103.15; X103.16; X103.17	X102.2; X102.3; X102.5; X102.6; X102.8; X102.9; X101.2; X101.3; X101.5; X101.6; X101.8; X101.9	X102.1; X102.4; X102.7; X102.11; X102.14; X102.17; X101.1; X101.4; X101.7; X101.11; X101.14; X101.17	X102.10; X102.12; X102.13; X102.15; X102.16; X102.18; X101.10; X101.12; X101.13; X101.15; X101.16; X101.18	X	CANopen	

ACCESSORIES

Description	Order number
Programming tool MRS Developers Studio	1.100.100.09
Cable set for programming CAN Relay Box	109639
Connector Kit CAN Relay Box	109637



MANUFACTURER

MRS Electronic, Inc.
6680 Poe Avenue Suite 100
Dayton OH, 45414

NOTES ON WIRING AND CABLE ROUTING

CAN bus communication is the main communication between the control unit and the vehicle. Therefore, connect the CAN bus with special care and check the correct communication with the vehicle to avoid undesired behavior.

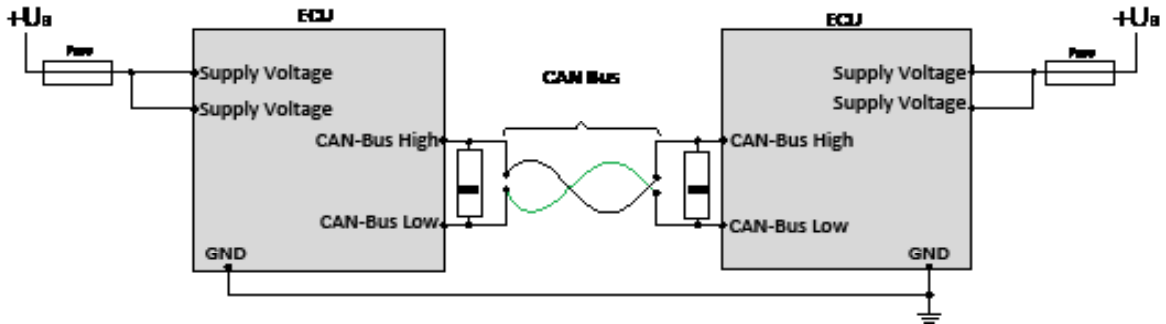

The COM connection for each relay must be protected separately from the supply voltage.

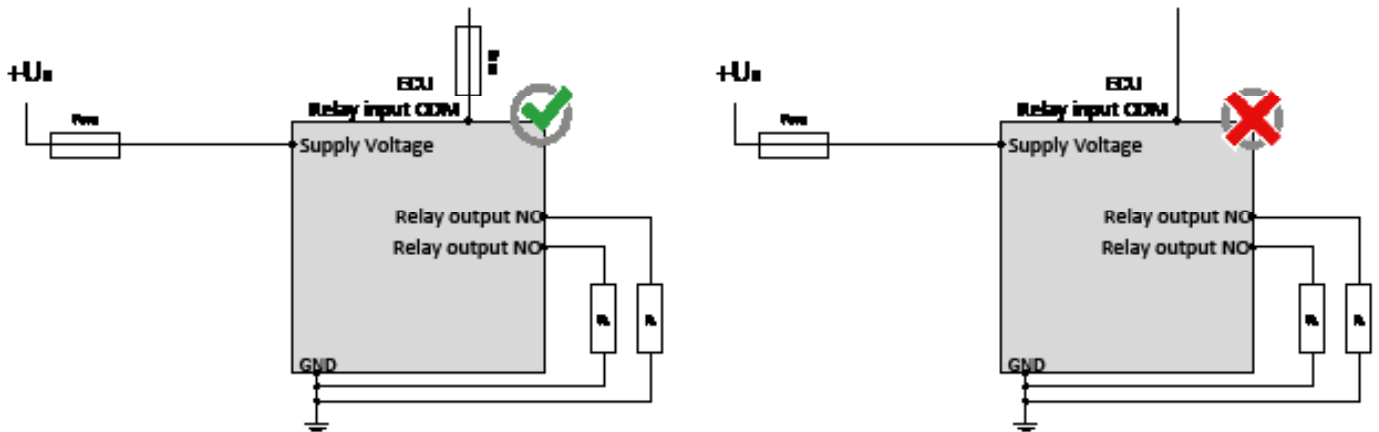

SAFETY AND INSTALLATION INFORMATION

It is essential to read the instructions in full thoroughly before working with the device.

Please note and comply with the instructions in the operating instructions and the information in the device data sheet, see www.mrs-electronic.com

Staff qualification: Only staff with the appropriate qualifications may work on this device or in its proximity.

SAFETY



WARNING! Danger as a result of a malfunction of the entire system.

Unforeseen reactions or malfunctions of the entire system may jeopardise the safety of people or the machine.

- Ensure that the device is equipped with the correct software and that the wiring and settings on the hardware are appropriate.



WARNING! Danger as a result of unprotected moving components.

Unforeseen dangers may occur from the entire system when putting the device into operation and maintaining it.

- Switch the entire system off before carrying out any work and prevent it from unintentionally switching back on.
- Before putting the device into operation, ensure that the entire system and parts of the system are safe.
- The device should never be connected or separated under load or voltage.



CAUTION! Risk of burns from the housing.

The temperature of the device housing may be elevated.

- Do not touch the housing and let all system components cool before working on the system.

PROPER USE

The device is used to control or switch one or more electrical systems or sub-systems in motor vehicles and machines and may only be used for this purpose. The device may only be used in an industrial setting.



WARNING! Danger caused by incorrect use.

The device is only intended for use in motor vehicles and machines.

- Use in safety-related system parts for personal protection is not permitted.
- Do not use the device in areas where there is a risk of explosion.

Correct use:

- operating the device within the operating areas specified and approved in the associated data sheet.
- strict compliance with these instructions and no other actions which may jeopardise the safety of individuals or the functionality of the device.

Obligations of the manufacturer of entire systems

It is necessary to ensure that only functional devices are used. If devices fail or malfunction, they must be replaced immediately.

System developments, installation and the putting into operation of electrical systems may only be carried out by trained and experienced staff who are sufficiently familiar with the handling of the components used and the entire system.

It is necessary to ensure that the wiring and programming of the device does not lead to safety-related malfunctions of the entire system in the event of a failure or a malfunction. System behaviour of this type can lead to a danger to life or high levels of material damage.

The manufacturer of the entire system is responsible for the correct connection of the entire periphery (e.g. cable cross sections, correct selection/connection of sensors/actuators).

Opening the device, making changes to the device and carrying out repairs are all prohibited. Changes or repairs made to the cabling can lead to dangerous malfunctions. Repairs may only be carried out by MRS.

Installation

The installation location must be selected so the device is exposed to as low a mechanical and thermal load as possible. The device may not be exposed to any chemical loads.

Install the device in such a manner that the plugs point downwards. This means condensation can flow off the device. Single seals on the cables/leads must be used to ensure that no water gets into the device.

Putting into operation

The device may only be put into operation by qualified staff. This may only occur when the status of the entire system corresponds to the applicable guidelines and regulations.

FAULT CORRECTION AND MAINTENANCE



NOTE The device is maintenance-free and may not be opened.

- If the device has damage to the housing, latches, seals or flat plugs, it must be taken out of operation.

Fault correction and cleaning work may only be carried out with the power turned off. Remove the device to correct faults and to clean it.

Check the integrity of the housing and all flat plugs, connections and pins for mechanical damage, damage caused by overheating, insulation damage and corrosion. In the event of faulty switching, check the software, switches and settings.

Do not clean the device with high pressure cleaners or steam jets. Do not use aggressive solvents or abrasive substances.