

This Datasheet is only valid for revision E (see label on the PLC). Please contact us for datasheets for other revisions (e.g. revision D).

DESCRIPTION

The Micro PLC is a small control for automotive applications. Free configuration, parameterization and programmability offer a wide range of application possibilities in the automotive sector.

TECHNICAL DATA

Housing	Plastic PA66GF30
Connector	Baseplate 9/5 pin (depending on assembly)
Weight	45 g
Temperature range acc. to ISO 16750-4	-40 °C...+85 °C (at +85 °C not full load)
Environmental protection acc. to ISO 20653	IP6K8 without potentiometer with correct mounting position (connection pins vertically downwards) and use of the waterproof socket otherwise IP40/IP20 (without/ with potentiometer)
Current consumption	depending on assembly/function
Quiescent current	unavailable
Over-current Protection	Compare max. current
Total Inputs and outputs	Depending on assembly
Input	Depending on assembly: digital inputs
Output	Depending on assembly: HSD outputs
Supply voltage	Depending on assembly, see supply voltage range starting page 6
Overvoltage protection	> 33 V
Reverse polarity protection	yes
Protection against inductive load	no

REGULATORY APPROVALS AND TESTING

E1 label	10 R - 06 8091
Electrical tests	<p>Acc. to ISO 16750-2 or -4: Short circuit (except pin C) Reverse voltage Disconnection of pin and connector Storage Test at T_{max} and T_{min} Operation Test at T_{max} and T_{min} Overvoltage at $T_{max} - 20\text{ °C}$ Load Dump (24 V, $R_i=8\ \Omega$, 12 V, $R_i=4\ \Omega$) Superimposed alternating voltage Slow decrease and increase of supply voltage Reset behavior at voltage drop</p> <p>Acc. to ISO 7637-2: Pulse 1, 2a, 2b, 3a, 3b, 4</p> <p>Acc. to ISO 10605: ESD (Pins: $\pm 4\text{ kV}$; Housing $\pm 8\text{ kV}$)</p>

SOFTWARE/PROGRAMMING

Programming system

The programming tool MRS Realizer is a suitable software for easy and fast programming of MRS-Controllers M1, M3, Micro PLC and the MRS-Proportional amplifier. Parameterization is easy by way of the relay contacts, thus you can save valuable time for open the housing. Easily create your own programs for your application via the Z-Graph. Therefore you will find graphic function blocks (based on IEC61131) in EAGLE™. You can download the new AUTODESK® EAGLE™ version according to your needs and requirements on the AUTODESK® EAGLE™ website.

Autodesk® is a registered trademark of Autodesk Inc, Eagle™ is a registered trademark of Autodesk Inc.

PIN ASSIGNMENT POWER SUPPLY AND PROGRAMMING INTERFACES (DEPENDING ON ASSEMBLY)

Pin	Description	Pin	Description
2	Supply voltage (Type S8,S9,S10)	5	HSD output (S9, S10)
3	Open collector output (optional S10)	6	GND
4	Switching input	8	HSD output (S8, S9, S10)

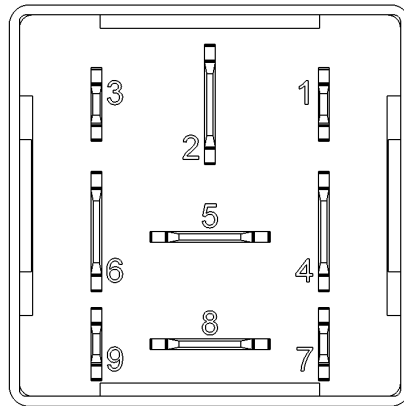

pin assignment 9 pin,
bottom view

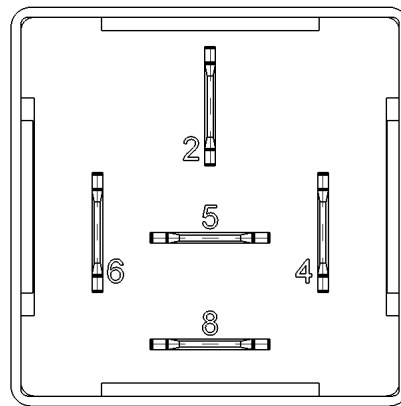

pin assignment 5 pin,
bottom view

PIN FEATURE MAP

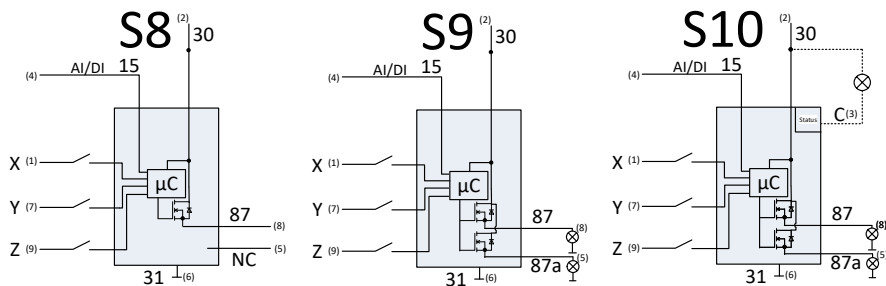
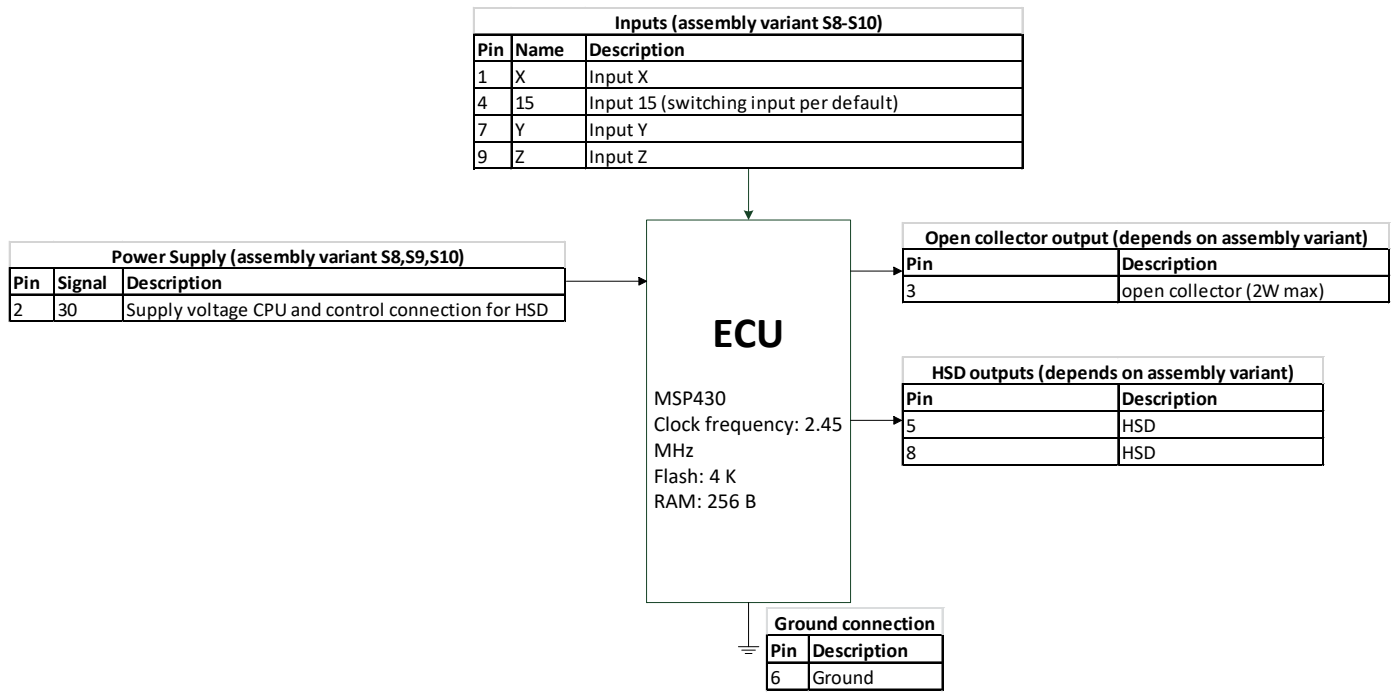

BLOCK FUNCTION DIAGRAM

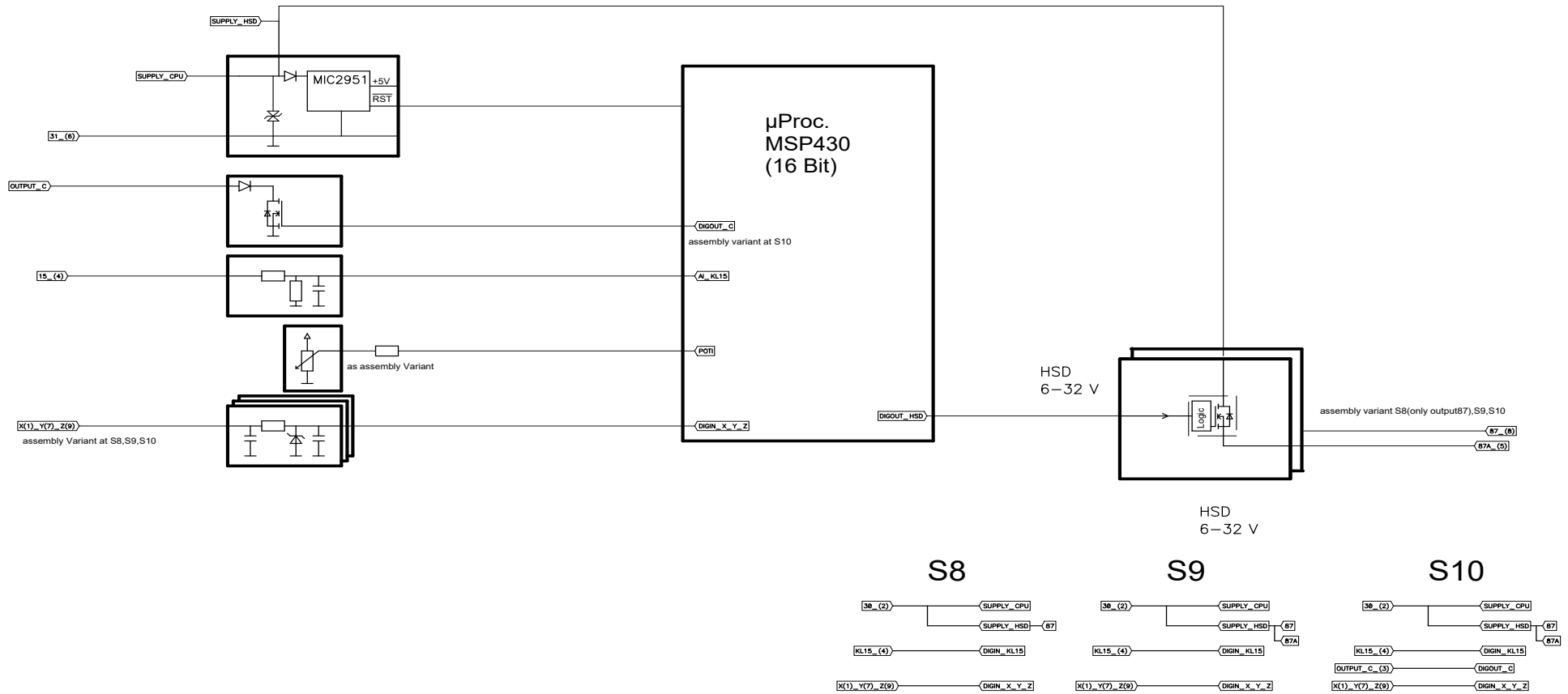

TECHNICAL DRAWING (IN MM)

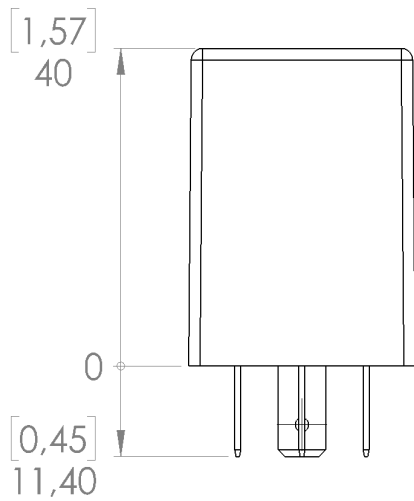
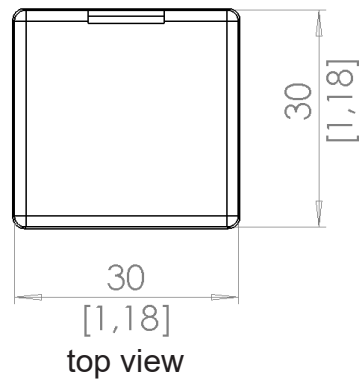

side view
9 pin

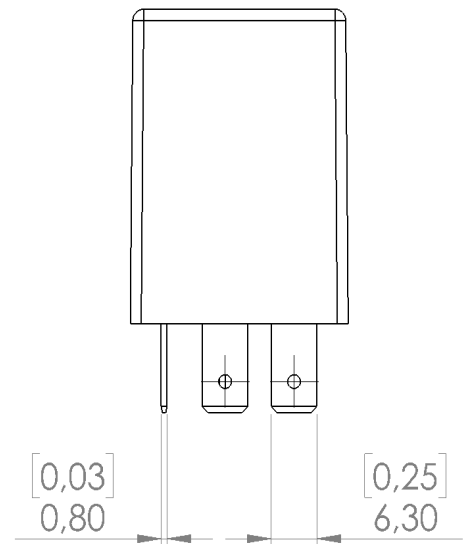

side view
5 pin

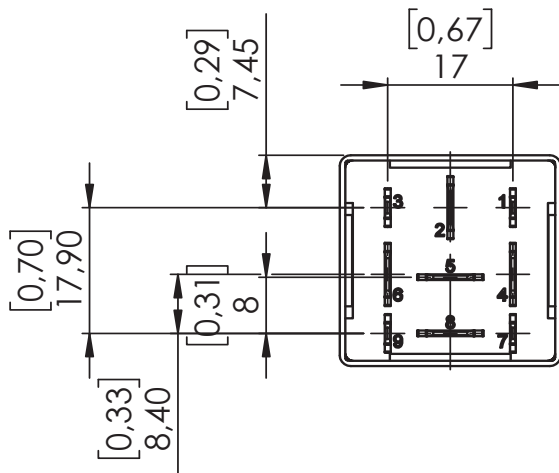

bottom view
9 pin

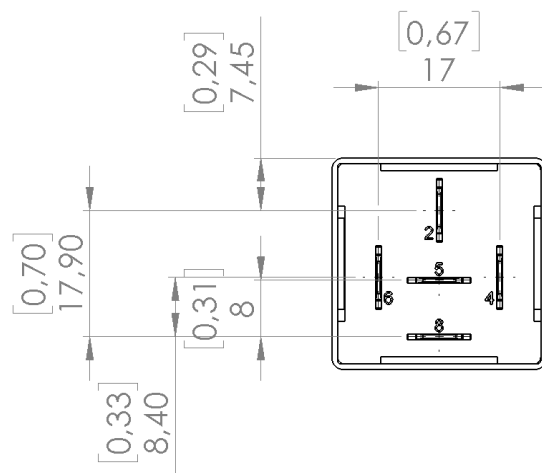

bottom view
5 pin



ASSEMBLY OPTIONS AND ORDER INFORMATION MICRO PLC

Order number	Number of pins	Supply voltage	Current consumption ¹	Supply μ C / output	Switching threshold switching input	Digital inputs		Pin assignment of outputs		Max. load output at 23 °C	Max. load output at 85°C
						X, Y, Z	C	C	HSD		
		See page 3 and 4	± 0.2 mA	Pin	Pin 4 KL15	X, Y, Z	C	C	HSD	max. load current HSD (BTS6143) 1 channel / 2 channels	max. load current HSD (BTS6143) 1 channel / 2 channels
1.005.355.00	9	12 + 24 V / S8	1.3 mA	2 / 2	programmable	1,7,9			8	15 A	12.5 A
1.005.365.00	9	12 + 24 V / S9	1.3 mA	2 / 2	programmable	1,7,9			5,8	15 A / 10 A	12.5 A / 8 A
1.005.371.00	9	12 + 24 V / S10	1.3 mA	2 / 2	programmable	1,7,9	3	3	5,8	15 A / 10 A	12.5 A / 8 A

¹ If supply voltage acc. to column 3 is applied

² measured at supply voltage = 28 V

ASSEMBLY OPTIONS AND ORDER INFORMATION RANGE MONITORING

Order number	Number of pins	Supply voltage	Current consumption ¹	Supply μ C / Relays	Switching threshold digital input	Pin assignment of outputs	Max. load output at 23 °C	Max. load output at 85 °C	Features
		see page 3 and 4	± 0.2 mA	Pin	Pin 4 ± 0.5 V ¹	HSD outputs	max. load current HSD (BTS6143)	max. load current HSD (BTS6143)	
1.008.300.xx	5	12 + 24 V / S8 ³	1.3 mA	2 / 2	assembly option	8	15 A	12.5 A	

¹ if supply voltage according to column 3 is applied (pickup voltage relay)

² measured at supply voltage = 28 V

³ S8 without digital inputs X, Y, Z

FUNCTION DESCRIPTION AND DIAGRAM RANGE MONITORING

The overvoltage monitors are used for voltage monitoring. The range monitoring switches off loads when certain threshold voltages exceed/deceed at terminal 15. If a certain threshold voltage is again exceeded/exceeded, the load is switched on again. The default values are 11.5 V / 12.5 V for 12 V and 23.5 V / 24.5 V for 24 V. The voltage thresholds can also be freely selected - please specify when ordering. Delay times are also possible. Please specify the desired range when ordering.

Voltage range

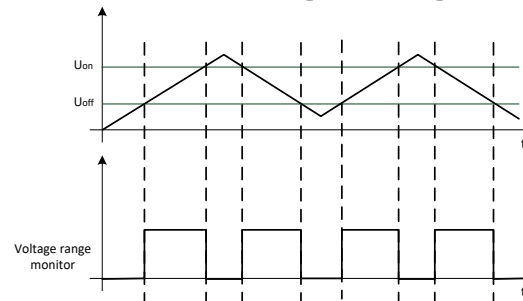

To prevent the switch from bouncing, we recommend programming an individual time delay, which is not included in the function diagram.

ASSEMBLY OPTIONS AND ORDER INFORMATION UNDERVOLTAGE MONITOR WITH RESET

Order number	Number of pins	Supply voltage	Current consumption	Supply μ C / HSD	Switching threshold digital input	Pin assignment of outputs	Max. load output at 23 °C ²	Max. load output at 85 °C ²	Features
		see page 3 and 4	± 0.2 mA	Pin	Pin 4 ± 0.5 V ¹	HSD outputs	max. load current HSD (BTS6143) 1 channel / 2 channels	max. load current HSD (BTS6143) 1 channel / 2 channels	
1.008.110.00	9	12 V / S10	1.3 mA	2 / 2	11.5 V / 12.5 V	5,8	15 A / 10 A	12.5 A / 8 A	When ordering, please specify individual voltage threshold (example: On: 11 V / Off: 13 V)
1.008.110.xx	9	12 V / S10	1.3 mA	2 / 2	order variant	5,8	15 A / 10 A	12.5 A / 8 A	
1.008.210.00	9	24 V / S10	1.3 mA	2 / 2	23 V / 25 V	5,8	15 A / 10 A	12.5 A / 8 A	
1.008.210.xx	9	24 V / S10	1.3 mA	2 / 2	order variant	5,8	15 A / 10 A	12.5 A / 8 A	
1.008.211.00	9	24 V / S8	1.3 mA	2 / 2	23 V / 25 V	8	15 A	12.5 A	
1.008.211.xx	9	24 V / S8	1.3 mA	2 / 2	order variant	8	15 A	12.5 A	

¹ If supply voltage acc. to column 3 is applied

² measured at supply voltage = 28 V

FUNCTION DESCRIPTION AND DIAGRAM UNDERVOLTAGE MONITOR WITH RESET

The Undervoltage Monitor With Reset (acknowledgment) has outputs for a signal, buzzer or other indicators. It can be used to turn on/off acoustic or optical warning signals when the input voltage drops below/exceeds a defined voltage level. When the input voltage applied to terminal 15 drops below the defined threshold voltage outputs 87, 87a, and C are turned on. Output 87 can be switched off again via reset input x (acknowledgement) while outputs 87a and C remain on. When the input voltage on terminal 15 exceeds the defined threshold voltage all outputs are switched off.

Function description similar, can be programmed individually (time delay, voltage limit).

To prevent the switch from bouncing, we recommend programming an individual time delay, which is not included in the function diagram.

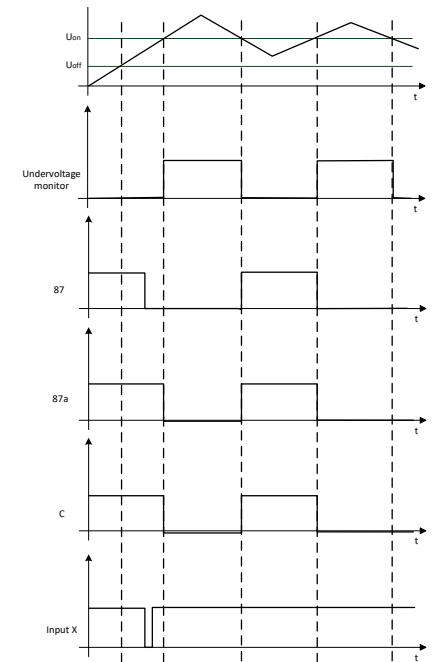
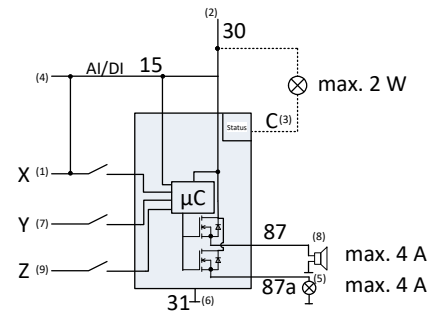



ASSEMBLY OPTIONS AND ORDER INFORMATION FREQUENCY MONITOR

Order number	Number of pins	Supply voltage	Current consumption ¹	Supply μ C / Relays	switching threshold digital input	Pin assignment of outputs	Max. load output at 23 °C ²	Max. load output at 85 °C ²	Features
		See page 3 and 4	± 0.2 mA	Pin	Pin 4 ± 0.5 V ¹	HSD outputs	max. load current HSD (BTS6143)	max. load current HSD (BTS6143)	
1.026.311.xxx	5	12 + 24 V / S8 ³	1.3 mA	2 / 2	6 V / 6 V	8	15 A	12.5 A	

¹ If supply voltage according to column 3 is applied (pickup voltage relay)

² measured at supply voltage = 28 V

³ S8 without digital inputs X, Y, Z

UNCTION DESCRIPTION AND DIAGRAM FREQUENCY MONITOR

The frequency monitor switches off consumers when certain threshold frequency is exceeded or not reached at terminal 15. The frequency thresholds can be freely selected, frequency range 10-1,000 Hz (with an accuracy of ± 2 %) please specify when ordering. Delay times are also possible.

ACCESSORIES

Description	Order number
Programming tool MRS Realizer	1.100.100.01
Parameterization station MRS	1.100.000.02
Socket package watertight 40 mm	1.017.010.40
Socket	1.017.002.00
FASTON terminal for latching 6.3 mm 1.5-2.5 mm ²	103064
FASTON terminal for latching 2.8 mm 0.5-1.0 mm ²	105292



MANUFACTURER

MRS Electronic, Inc.
 6680 Poe Avenue Suite 100
 Dayton OH, 45414
 USA

NOTES ON WIRING AND CABLE ROUTING

The module must be protected against overcurrent with a suitable fuse.

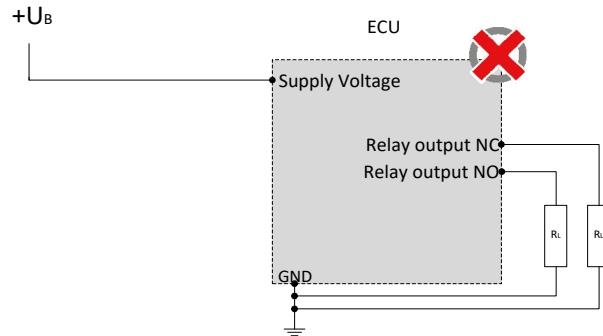
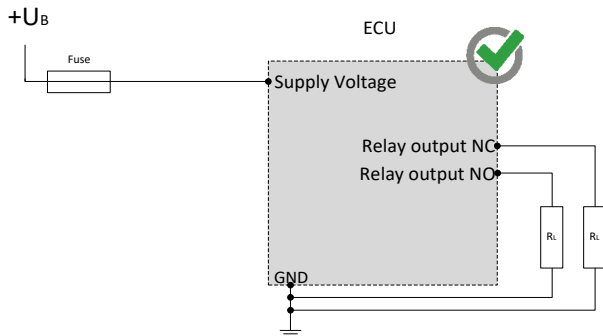

High-side driver outputs may only be connected to ground.

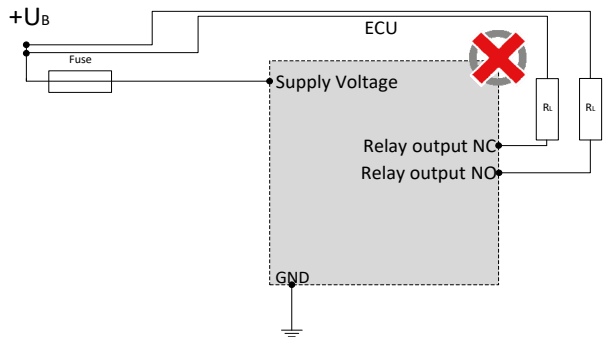
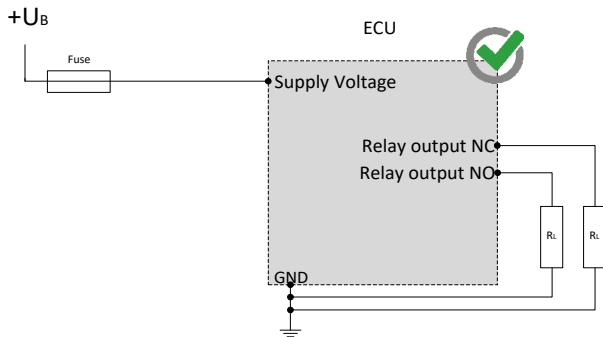

The open collector output may only be connected to supply voltage.

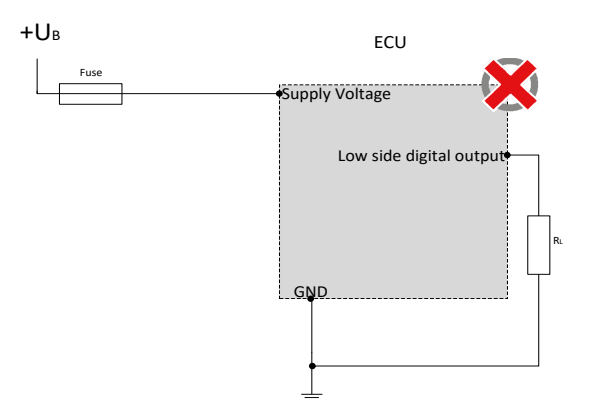
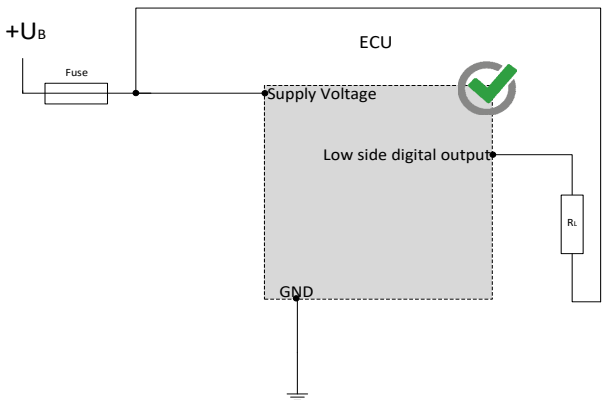

SAFETY AND INSTALLATION INFORMATION

It is essential to read the instructions in full thoroughly before working with the device.

Please note and comply with the instructions in the operating instructions and the information in the device data sheet, see www.mrs-electronic.com

Staff qualification: Only staff with the appropriate qualifications may work on this device or in its proximity.

SAFETY



WARNING! Danger as a result of a malfunction of the entire system.

Unforeseen reactions or malfunctions of the entire system may jeopardise the safety of people or the machine.

- Ensure that the device is equipped with the correct software and that the wiring and settings on the hardware are appropriate.



WARNING! Danger as a result of unprotected moving components.

Unforeseen dangers may occur from the entire system when putting the device into operation and maintaining it.

- Switch the entire system off before carrying out any work and prevent it from unintentionally switching back on.
- Before putting the device into operation, ensure that the entire system and parts of the system are safe.
- The device should never be connected or separated under load or voltage.



CAUTION! Risk of burns from the housing.

The temperature of the device housing may be elevated.

- Do not touch the housing and let all system components cool before working on the system.

PROPER USE

The device is used to control or switch one or more electrical systems or sub-systems in motor vehicles and machines and may only be used for this purpose. The device may only be used in an industrial setting.



WARNING! Danger caused by incorrect use.

The device is only intended for use in motor vehicles and machines.

- Use in safety-related system parts for personal protection is not permitted.
- Do not use the device in areas where there is a risk of explosion.

Correct use:

- operating the device within the operating areas specified and approved in the associated data sheet.
- strict compliance with these instructions and no other actions which may jeopardise the safety of individuals or the functionality of the device.

Obligations of the manufacturer of entire systems

It is necessary to ensure that only functional devices are used. If devices fail or malfunction, they must be replaced immediately.

System developments, installation and the putting into operation of electrical systems may only be carried out by trained and experienced staff who are sufficiently familiar with the handling of the components used and the entire system.

It is necessary to ensure that the wiring and programming of the device does not lead to safety-related malfunctions of the entire system in the event of a failure or a malfunction. System behaviour of this type can lead to a danger to life or high levels of material damage.

The manufacturer of the entire system is responsible for the correct connection of the entire periphery (e.g. cable cross sections, correct selection/connection of sensors/actuators).

Opening the device, making changes to the device and carrying out repairs are all prohibited. Changes or repairs made to the cabling can lead to dangerous malfunctions. Repairs may only be carried out by MRS.

Installation

The installation location must be selected so the device is exposed to as low a mechanical and thermal load as possible. The device may not be exposed to any chemical loads.

Install the device in such a manner that the plugs point downwards. This means condensation can flow off the device. Single seals on the cables/leads must be used to ensure that no water gets into the device.

Putting into operation

The device may only be put into operation by qualified staff. This may only occur when the status of the entire system corresponds to the applicable guidelines and regulations.

FAULT CORRECTION AND MAINTENANCE



NOTE The device is maintenance-free and may not be opened.

- If the device has damage to the housing, latches, seals or flat plugs, it must be taken out of operation.

Fault correction and cleaning work may only be carried out with the power turned off. Remove the device to correct faults and to clean it.

Check the integrity of the housing and all flat plugs, connections and pins for mechanical damage, damage caused by overheating, insulation damage and corrosion. In the event of faulty switching, check the software, switches and settings.

Do not clean the device with high pressure cleaners or steam jets. Do not use aggressive solvents or abrasive substances.