

Angled view

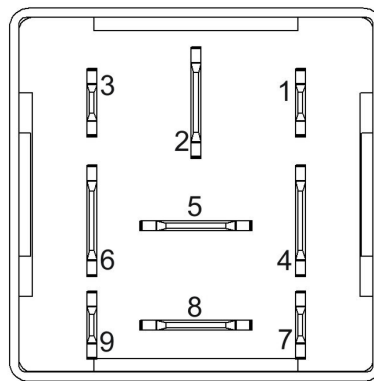

Plug view

## DESCRIPTION

The Micro PLC CAN Relay 32-bit combines Micro PLC CAN 12 V and 24 V in one product and can be used flexibly in a voltage range of 9-32V. With its 32-bit processor, the compact CAN controller delivers even more computing power than the previous version and offers you a wide range of applications in the automotive sector thanks to its free configurability, parameterization and programmability.

## TECHNICAL DATA

Housing	Plastic PA66GF30
Connector	Base plate 9-pin
Weight	35 g
Temperature range (acc. to ISO 16750-4)	-40°C...+85 °C
Environmental protection (Acc. to ISO 20653)	IP 6K8 with correct mounting direction and use of the waterproof plug-in socket, otherwise IP53
Current consumption	32 mA at 12 V / 19 mA at 24 V
Fuse protection	<b>Variant S40:</b> 1 A + Load Relay output at Pin 2 <b>Variant S41 (2 fuses required):</b> Load Relay output at Pin 2 1 A (CPU) at Pin 3
Total inputs and output	3 resp. 2, depending on assembly variant, compare p. 7
Inputs	<b>Depending on assembly variant and configurable:</b> 1x or 2x Analog input 0...16.7 V, switchable 0...32 V Digital, positive signals Frequency input Sensor input 1x switchable to current input (330 Ω vs. GND)
Outputs	Digital (Relay output)
Supply voltage	11 V...32 V (-40°C...+85°C) 10 V...32 V (-30°C...+80°C) 6 V...32 V (-40°C...+85°C, without relay)
Overvoltage protection	Above ~ 36.5 V active pulse reduction
Quiescent current	< 25 µA
Reverse polarity protection	Yes
CAN interfaces	CAN Interface 2.0 A/B, ISO 11898-2:2003, CAN-FD capable

## REGULATORY APPROVALS AND TESTING

E1 approval	06 10046
Electrical tests	<b>Acc. to ISO 16750 – 2 bzw. -4:</b> Short circuit Reverse polarity disconnection pin and connector Long-term overvoltage at $T_{Max-20K}$ storage test at $T_{Max}$ and $T_{Min}$ Operation test at $T_{Max}$ und $T_{Min}$ Temperature steps Ground offset superimposed alternating voltage Slow decrease and increase of supply voltage Momentary drop in supply voltage Reset behaviour at voltage drop Starting profile (form. Pulse 4) Load Dump  <b>Acc. to ISO 7637 - 2:</b> Puls 1, 2a, 2b, 3a, 3b  <b>Acc. to ISO 10605 2008:</b> ESD: Housing ±15 kV, Pins ±8 kV ESD indirect discharge on discharge islands: ±15 kV

## SOFTWARE/PROGRAMMING

Programming System

### MRS APPLICS STUDIO

The Applics Studio is the new development and tool platform for our assemblies. Program your MRS controls quickly and easily with our stand-alone software. The focus is on your application.

## INPUT FEATURES - SUMMARY (DEPENDING ON ASSEMBLY)

Pin X (1)			Pin C (3)		
programmable as analog- or digital input			programmable as analog- or digital input		
Resolution 12 Bit			Resolution 12 Bit		
Deviation $\pm 1\%$ full scale			Deviation $\pm 1\%$ full scale		
Voltage Input 0...16.7 V (see <a href="#">A</a> ) <sup>1</sup>	Input resistance	31 k $\Omega$	Voltage Input 0...16.7 V (see <a href="#">A</a> ) <sup>1</sup>	Input resistance	34 k $\Omega$
	Input frequency	$f_g^2 = 125$ Hz		Input frequency	$f_g^2 = 125$ Hz
	Deviation	$\pm 3\%$ above 2 V		Deviation	$\pm 3\%$ above 2 V
Voltage Input 0...32 V (see <a href="#">A</a> )	Input resistance	28 k $\Omega$	Voltage Input 0...32 V (see <a href="#">A</a> )	Input resistance	28 k $\Omega$
	Input frequency	$f_g^2 = 220$ Hz		Input frequency	$f_g^2 = 220$ Hz
	Deviation	$\pm 3\%$ above 2 V		Deviation	$\pm 3\%$ above 2 V
Digital Input positive (see <a href="#">C</a> ) <sup>3</sup>	Input resistance	31 k $\Omega$	Digital Input positive (see <a href="#">C</a> ) <sup>3</sup>	Input resistance	31 k $\Omega$
	Switch-on threshold	6.0 V		Switch-on threshold	6.0 V
	Switch-off threshold	3.9 V		Switch-off threshold	3.9 V
Frequency Input 0...14 kHz (see <a href="#">B</a> ) <sup>3</sup>	Input resistance	31 k $\Omega$	Frequency Input 0...14 kHz (see <a href="#">B</a> ) <sup>3</sup>	Input resistance	31 k $\Omega$
	Switch-on threshold	3.0 V $\pm 0.3$ V		Switch-on threshold	3.0 V $\pm 0.3$ V
	Switch-off threshold	2.3 V $\pm 0.3$ V		Switch-off threshold	2.3 V $\pm 0.3$ V
	Min. pulse width	5 $\mu$ s		Min. pulse width	5 $\mu$ s
	meas. range PWM	3...93 %		meas. range PWM	3...93 %
	Deviation	$\pm 3\%$		Deviation	$\pm 3\%$
Sensor Input (see <a href="#">E</a> )	Input resistance	1 k $\Omega$ vs internal 5 V	Sensor Input (see <a href="#">E</a> )	Input resistance	1 k $\Omega$ vs internal 5 V
Current Input 0...27.5 mA (see <a href="#">C</a> ) <sup>4</sup>	Input resistance	330 $\Omega$ vs. GND			
	Conversion factor	1 mA $\approx$ 83.5 digits			
	Deviation	$\pm 3\%$ >2 mA			

<sup>1</sup> Standard configuration

<sup>2</sup> Cut-off frequency (-3 dB), measrued with 10 V<sub>Peak</sub> square signal

<sup>3</sup> when using standard configuration, see <sup>1</sup>

<sup>4</sup> When using the pulldown, no higher voltage than 8.5 V may be applied, otherwise the pulldown is automatically deactivated for safety reasons

## OUPUT FEATURES - SUMMARY

**Pin 87, 87A**  
**Relay Ouputs**

Load current <sup>5</sup> (Relay, see <a href="#">D</a> )	NO	10 A
	NC	5 A

<sup>5</sup> tested with resistive Load, at 85°C

PIN ASSIGNMENT POWER SUPPLY AND INTERFACES

Pin	Pin Description	Pin	Pin Description
2	Contact 30 / supply voltage (Type S40) / connection potential free Relay COM (Type S41)	6	KL31 / GND
3	Contact 30 / supply voltage (Typ S41)	7	CAN-Bus High
4	Contact 15 / ignition	9	CAN-Bus Low

PIN ASSIGNMENT INPUTS AND OUTPUTS

Pin	Signal	Pin Description	Pin	Signal	Pin Description
1	AI_X DO_RANGE_X DI_AI_X FREQ_X DO_PD_X DO_PU_X	Analog input X 0...16.7 resp. 0...32 V or Digital input X or Frequency input X or Current input X or Sensor input X	5		NC-Output Relay
3	AI_C DO_RANGE_C DI_AI_C FREQ_C DO_PU_C	Analog input C 0...16.7 resp. 0...32 V or Digital input C or Frequency input C or Sensor input C (Typ S40)	8	DO_RELAY	NO-Output Relay

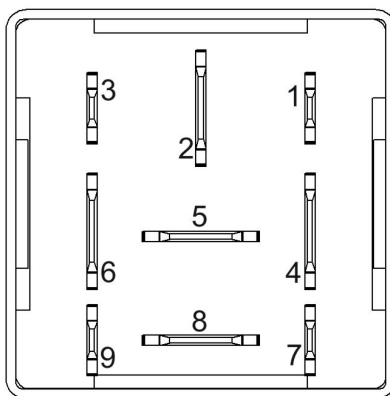

Pin assignment, plug view

CONNECTION DIAGRAM

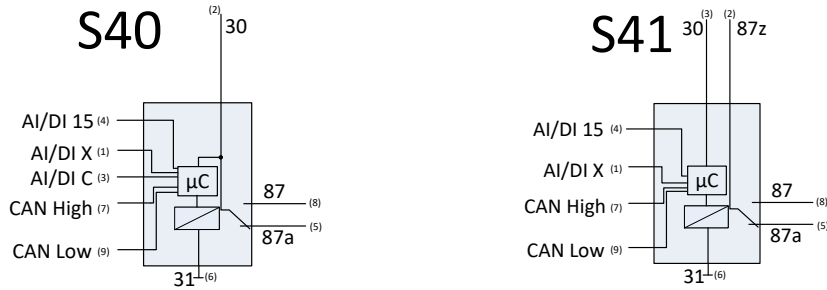

PIN FEATURE MAP

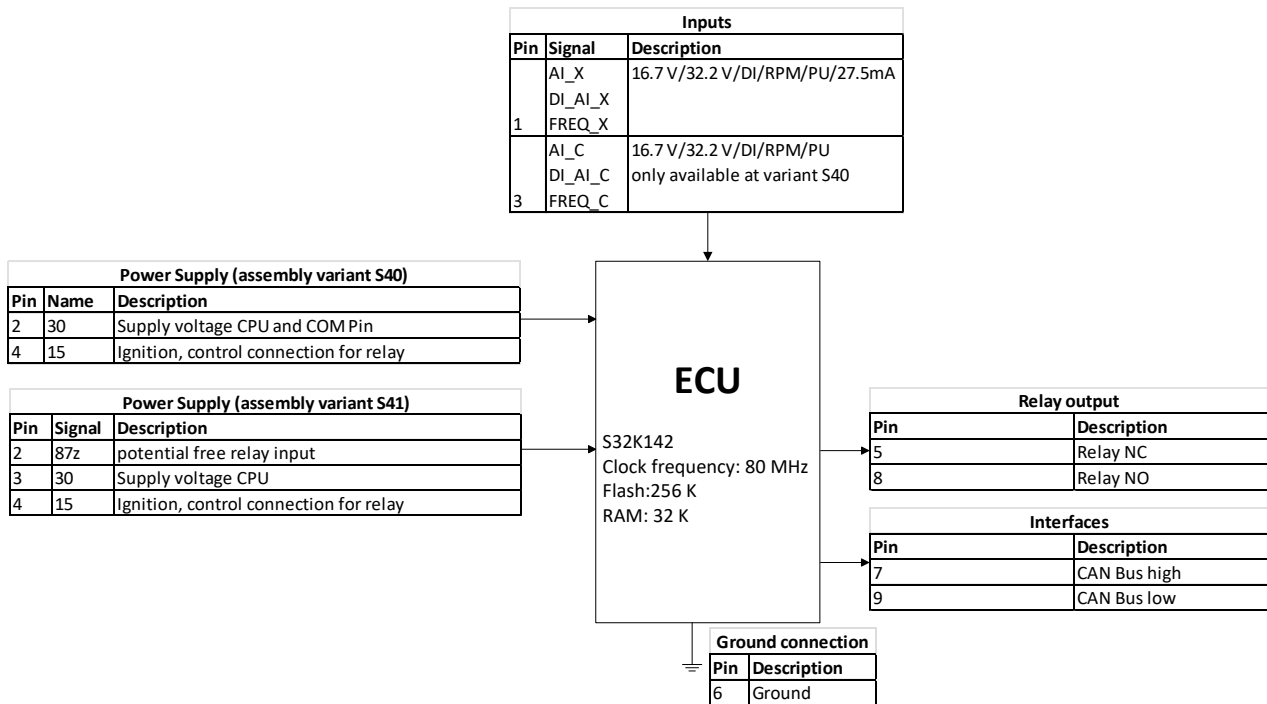

BLOCK FUNCTION DIAGRAM

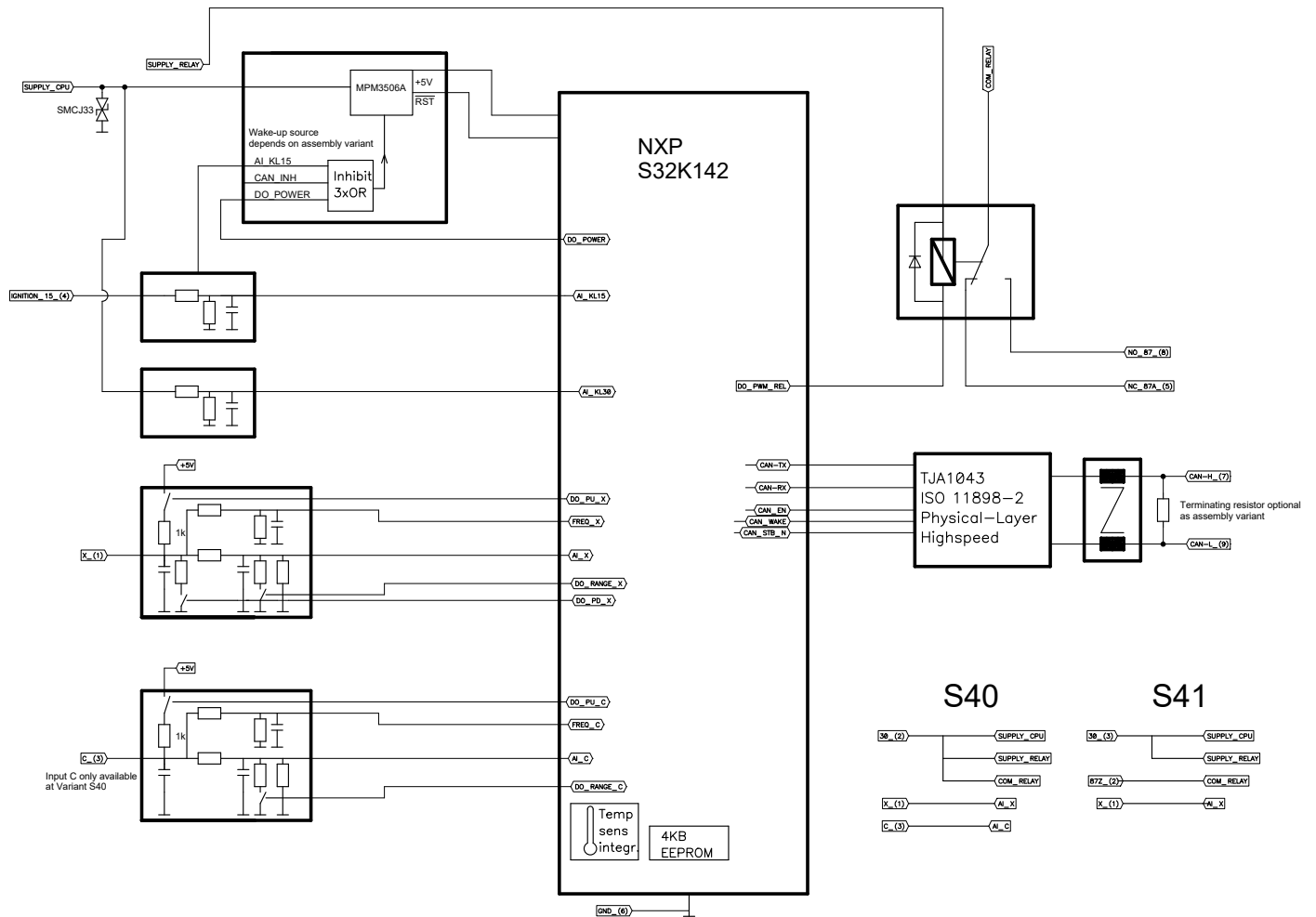

TECHNICAL DRAWING IN MM (IN INCH)

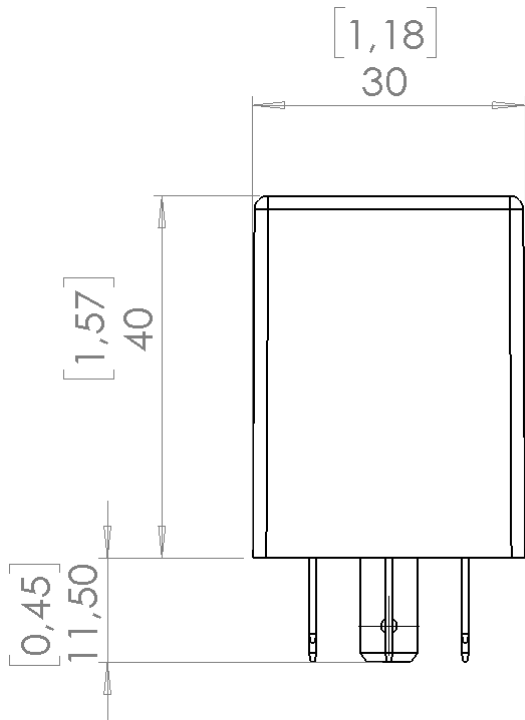

Side view

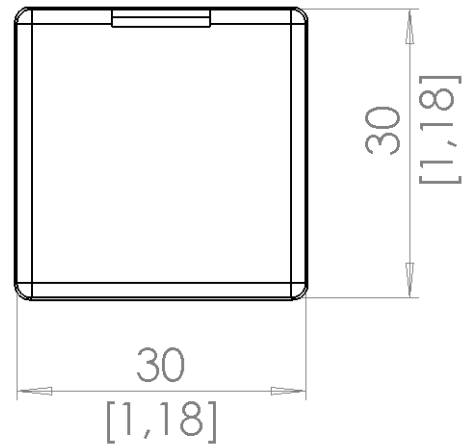

Top view

## ASSEMBLY OPTIONS AND ORDER INFORMATION

	Variant	Pin numbering of the inputs					Pin numbering of the outputs	CAN Bus	Wake up sources	Remarks
		A Voltage 0...16.7 V or 0...32.2 V	B Digital input	C Frequen- cy input Hz	D Sensor input 1 k $\Omega$ pull- up	E current Input 0...27.5 mA				
	see p. 4						F Relay outputs (NC, NO)	High-Speed, CAN-FD-ca- pable		
<b>1.158.300.0000</b>	S40	1, 3	1, 3	1, 3	1, 3	1	5, 8	X	CAN, Contact 15	
<b>1.158.301.0000</b>	S41	1	1	1	1	1	5, 8 (potential free)	X	CAN, Contact 15	
<b>1.158.310.0000</b>	S40	1, 3	1, 3	1, 3	1, 3	1	5, 8	X	CAN, Contact 15	120 $\Omega$ CAN-Bus Termination resistance integrated
<b>1.158.311.0000</b>	S41	1	1	1	1	1	5, 8 (potential free)	X	CAN, Contact 15	120 $\Omega$ CAN-Bus Termination resistance integrated
<b>1.158.320.0000</b>	S40	1, 3	1, 3	1, 3	1, 3	1	5, 8	X	Contact 15	
<b>1.158.321.0000</b>	S41	1	1	1	1	1	5, 8 (potential free)	X	Contact 15	
<b>1.158.330.0000</b>	S40	1, 3	1, 3	1, 3	1, 3	1	5, 8	X	Contact 15	120 $\Omega$ CAN-Bus Termination resistance integrated
<b>1.158.331.0000</b>	S41	1	1	1	1	1	5, 8 (potential free)	X	Contact 15	120 $\Omega$ CAN-Bus Termination resistance integrated

## ACCESSORIES

Description	Order number
Applics Studio Bundle	1.100.200.00
PCAN-USB Interface FD	503750
Programming cable set	109446
Socket	1.017.002.00
Tab receptacle for latching for 6,3 mm/1,5-2,5 mm <sup>2</sup>	103064
Tab receptacle for latching for 2,8 mm/0,5-1,0 mm <sup>2</sup>	105292
Connector package watertight socket 30x30x40	1.017.010.40

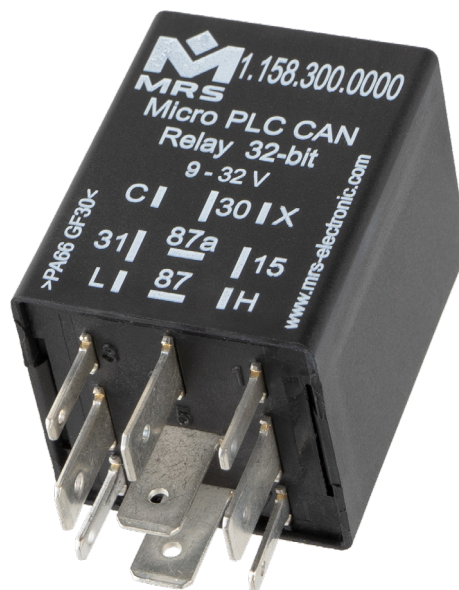

Sample image

## MANUFACTURER

MRS Electronic GmbH & Co. KG  
 Klaus-Gutsch-Str. 7  
 78628 Rottweil  
 Germany



NOTES ON WIRING AND CABLE ROUTING

The module must be protected against overcurrent with a suitable fuse.

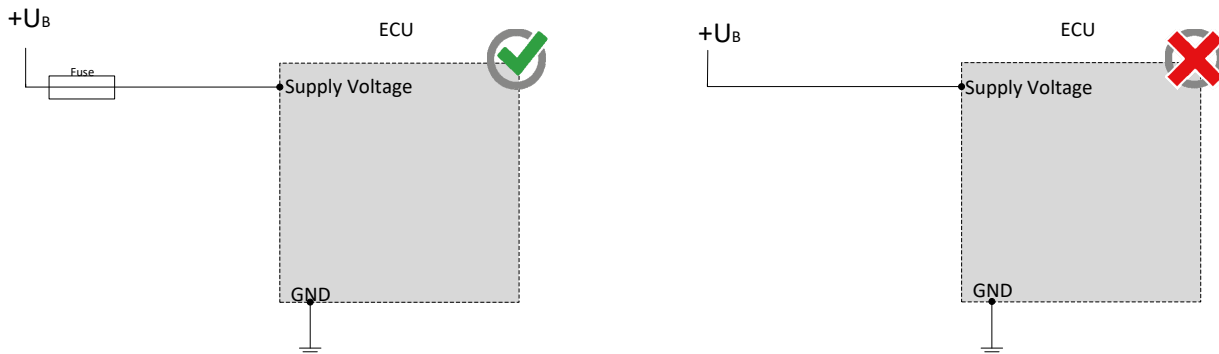

The common contact of the relay must be fused separately for the S41 variant.

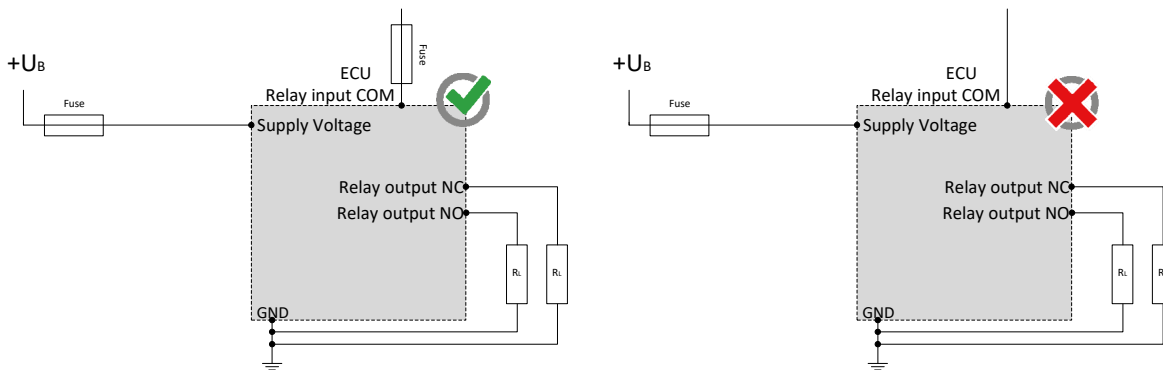

When using the input with pull-down resistance (using PD\_X), you must not connect a greater voltage than 9 V to the input.

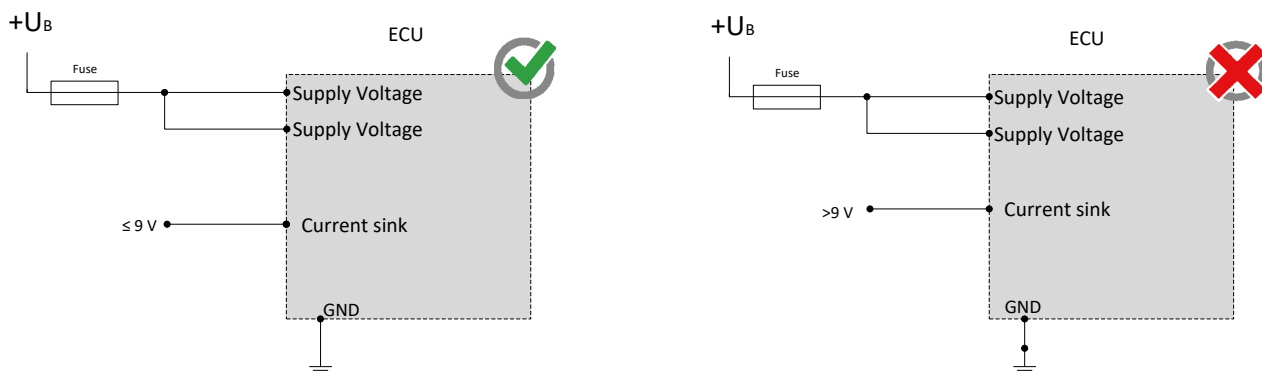

CAN bus communication is the main communication between the control unit and the vehicle. Therefore, connect the CAN bus with special care and check the correct communication with the vehicle to avoid undesired behavior.

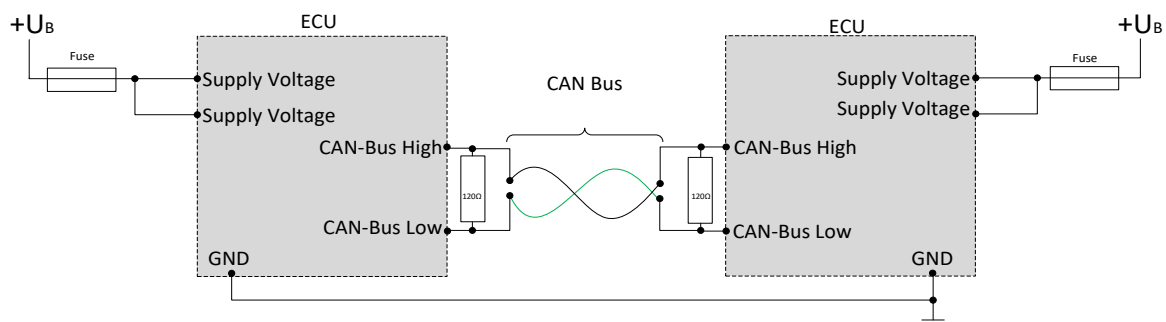

## SAFETY AND INSTALLATION INFORMATION

It is essential to read the instructions in full thoroughly before working with the device.

Please note and comply with the instructions in the operating instructions and the information in the device data sheet, see [www.mrs-electronic.de](http://www.mrs-electronic.de)

**Staff qualification:** Only staff with the appropriate qualifications may work on this device or in its proximity.

### SAFETY



**WARNING! Danger as a result of a malfunction of the entire system.**

Unforeseen reactions or malfunctions of the entire system may jeopardise the safety of people or the machine.

- Ensure that the device is equipped with the correct software and that the wiring and settings on the hardware are appropriate.



**WARNING! Danger as a result of unprotected moving components.**

Unforeseen dangers may occur from the entire system when putting the device into operation and maintaining it.

- Switch the entire system off before carrying out any work and prevent it from unintentionally switching back on.
- Before putting the device into operation, ensure that the entire system and parts of the system are safe.
- The device should never be connected or separated under load or voltage.



**CAUTION! Risk of burns from the housing.**

The temperature of the device housing may be elevated.

- Do not touch the housing and let all system components cool before working on the system.

### PROPER USE

The device is used to control or switch one or more electrical systems or sub-systems in motor vehicles and machines and may only be used for this purpose. The device may only be used in an industrial setting.



**WARNING! Danger caused by incorrect use.**

The device is only intended for use in motor vehicles and machines.

- Use in safety-related system parts for personal protection is not permitted.
- Do not use the device in areas where there is a risk of explosion.

**Correct use:**

- operating the device within the operating areas specified and approved in the associated data sheet.
- strict compliance with these instructions and no other actions which may jeopardise the safety of individuals or the functionality of the device.

**Obligations of the manufacturer of entire systems**

It is necessary to ensure that only functional devices are used. If devices fail or malfunction, they must be replaced immediately.

System developments, installation and the putting into operation of electrical systems may only be carried out by trained and experienced staff who are sufficiently familiar with the handling of the components used and the entire system.

It is necessary to ensure that the wiring and programming of the device does not lead to safety-related malfunctions of the entire system in the event of a failure or a malfunction. System behaviour of this type can lead to a danger to life or high levels of material damage.

The manufacturer of the entire system is responsible for the correct connection of the entire periphery (e.g. cable cross sections, correct selection/connection of sensors/actuators).

Opening the device, making changes to the device and carrying out repairs are all prohibited. Changes or repairs made to the cabling can lead to dangerous malfunctions. Repairs may only be carried out by MRS.

**Installation**

The installation location must be selected so the device is exposed to as low a mechanical and thermal load as possible. The device may not be exposed to any chemical loads.

Install the device in such a manner that the plugs point downwards. This means condensation can flow off the device. Single seals on the cables/leads must be used to ensure that no water gets into the device.

**Putting into operation**

The device may only be put into operation by qualified staff. This may only occur when the status of the entire system corresponds to the applicable guidelines and regulations.

### FAULT CORRECTION AND MAINTENANCE



**NOTE The device is maintenance-free and may not be opened.**

- If the device has damage to the housing, latches, seals or flat plugs, it must be taken out of operation.

Fault correction and cleaning work may only be carried out with the power turned off. Remove the device to correct faults and to clean it.

Check the integrity of the housing and all flat plugs, connections and pins for mechanical damage, damage caused by overheating, insulation damage and corrosion. In the event of faulty switching, check the software, switches and settings.

Do not clean the device with high pressure cleaners or steam jets. Do not use aggressive solvents or abrasive substances.