

mounting direction

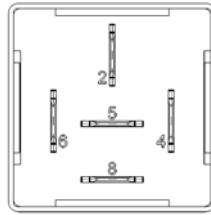

view of plug

DESCRIPTION

With the toggle relay, a load can be switched with a button. If a switching threshold is detected at terminal 15, the relay switches and holds itself. With a further over- or undershoot, the relay switches again (toggle flip-flop).

TECHNICAL DATA

Housing	Plastic PA66GF30
Connector	Base plate 5-pin
Weight	45 g
Temperature range (ISO 16750-4 compliant)	-40°C to +85 °C (at +85 °C not full load)
Environmental Protection	IP 6K8, when using the socket package watertight and correct installation position (plug vertical down)
Current consumption (NO/NC)	1.001.100.01: 10 mA / 120 mA 1.001.102.01: 10 mA / 120 mA 1.002.200.01: 10 mA / 80 mA 1.002.202.01: 10 mA / 80 mA
Over-current Protection	1 A + Load
Total Inputs and outputs	1 switching input / 1 Relay output (NO, NC)
Input	Digital
Output	1 relay output (NO, NC)
Operating voltage	See p. 5
Overvoltage protection	>33 V
Reverse polarity protection	Yes

REGULATORY APPROVALS AND TESTING

E1 approval	ECE R10 05 8780
EMV	2014/30/EU
Electrical tests	According to ISO 16750 – 2 resp. -4: Short circuit protection Reverse polarity Jump start Storage test at TMax and TMin Operation test at TMax and TMin According to ISO 7637 - 2: Puls 1, 2a, 2b, 3a, 3b BCI according to ISO 11452-4: 3. edition 2005 and improvement 1 2009 free field testing according to ISO 11452-2: 2. edition 2004)

PIN ASSIGNMENT POWER SUPPLY AND INTERFACES

Pin	Description	Pin	Description
2	switching input/contact 15	5	Relay output NC
4	GND	6	Supply voltage/contact 30
		8	Relay output NC

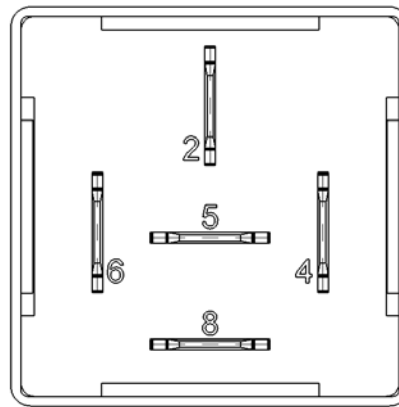

Pin assignment, bottom view

CONNECTION DIAGRAM

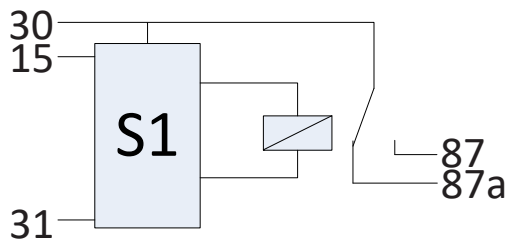



PIN FEATURE MAP

Power Supply		
Pin	Name	Description
2	15	Ignition, control connection for relay
6	30	Supply voltage CPU and COM Pin



Relay outputs	
Pin	Description
5	Relay NC
8	Relay NO

Ground connection	
Pin	Description
4	Ground

BLOCK FUNCTION DIAGRAM

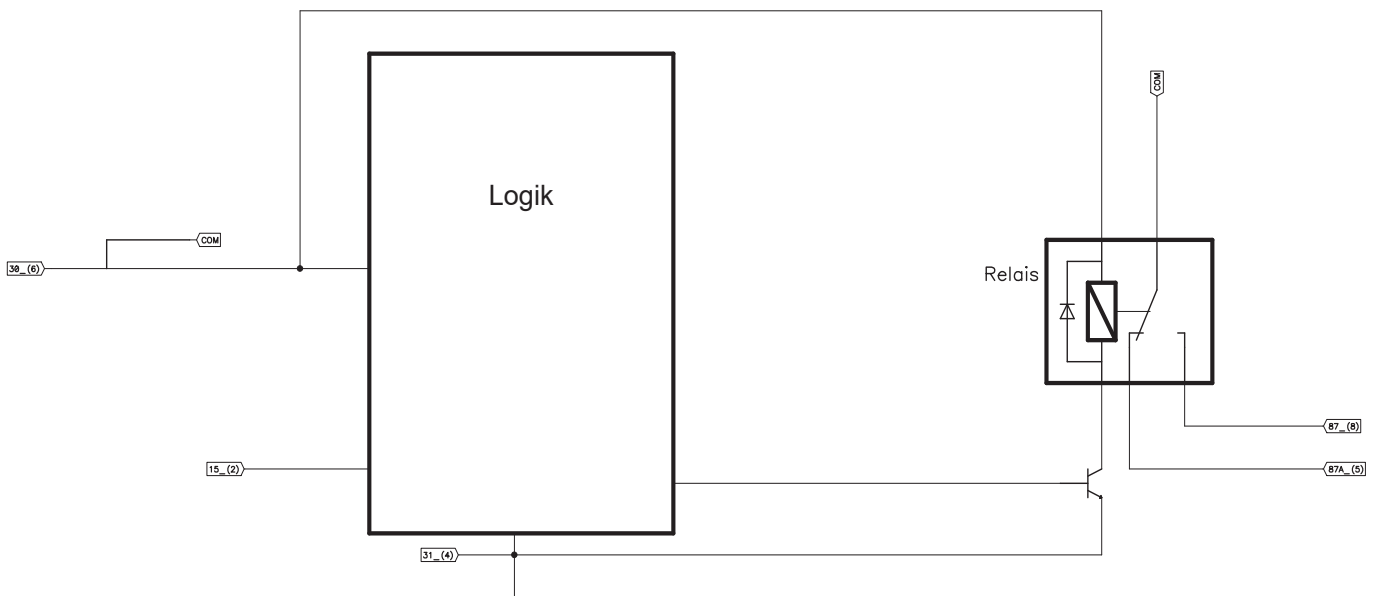

TECHNICAL DRAWING (IN MM)

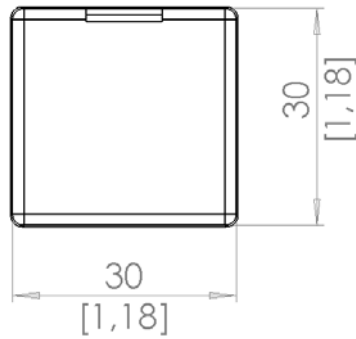

aerial view

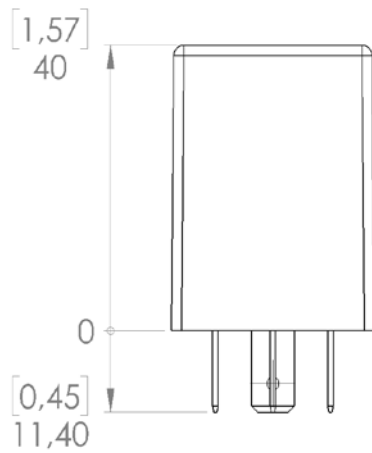

side view

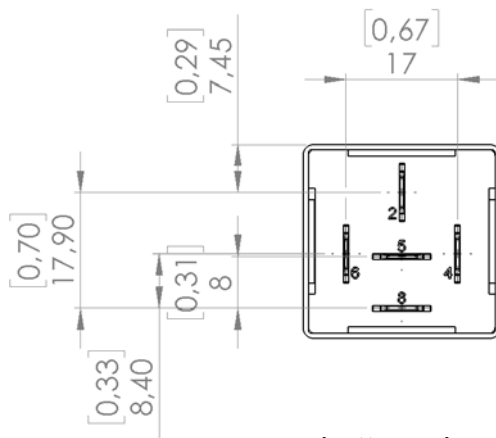

bottom view



ASSEMBLY OPTIONS AND ORDER INFORMATION TOGGLE RELAYS

Order no.	Supply voltage	Supply logic circuit / relay	Switching threshold digital input	Min. pulse width switching input	Pin assignment of outputs	Max. output load at +85°C	Operating voltage range	Features
		Pin	Pin 2 $\pm 0.3 \text{ V}^1$ LH/HL	Pin 2 $\pm 0.5 \text{ mS}^1$ high/low	Relay outputs	Relay outputs 3s NO/ 3s NC		
1.001.100.01	12 V	6 / 6	7.5 / 7.5	5.5 mS / 6.5 mS	5,8	20A NC/20 A NO	9-16 V	KL15 positive-switching (see P. 6)
1.001.102.01	12 V	6 / 6	2.6 / 2.6	6.5 mS / 4.5 mS	5,8	20 A NC/20 A NO	9-16 V	KL15 ground-switching (see P. 6)
1.001.200.01	24 V	6 / 6	7.2 / 7.2	5.5 mS / 5.5 mS	5,8	15 A NC/15 A NO	14-32 V	KL15 positive-switching (see P. 6)
1.001.202.01	24 V	6 / 6	3.0 / 3.0	6.0 mS / 4.5 mS	5,8	15 A NC/15 A NO	14-32 V	KL15 ground-switching (see P. 6)

¹ If supply voltage according to column 2 is present (relay tension voltage)

FUNCTIONAL DESCRIPTION TOGGLE RELAYS

With the toggle relay, a load can be switched with a button. If a switching threshold is detected at terminal 15, the relay switches and holds itself. With a further over- or undershoot, the relay switches again (toggle flip-flop).



FUNCTION DIAGRAM

positive switching

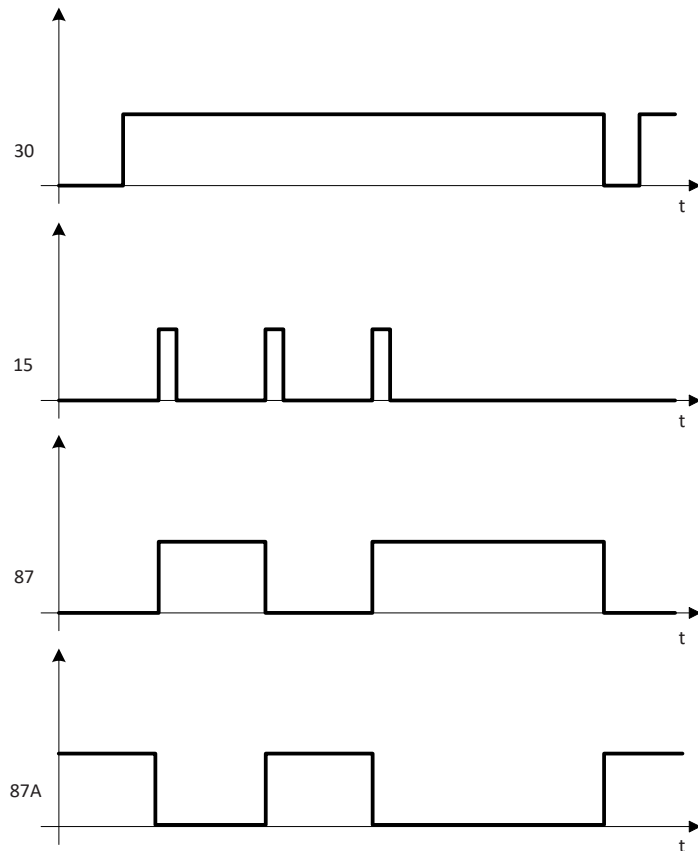

ground switching

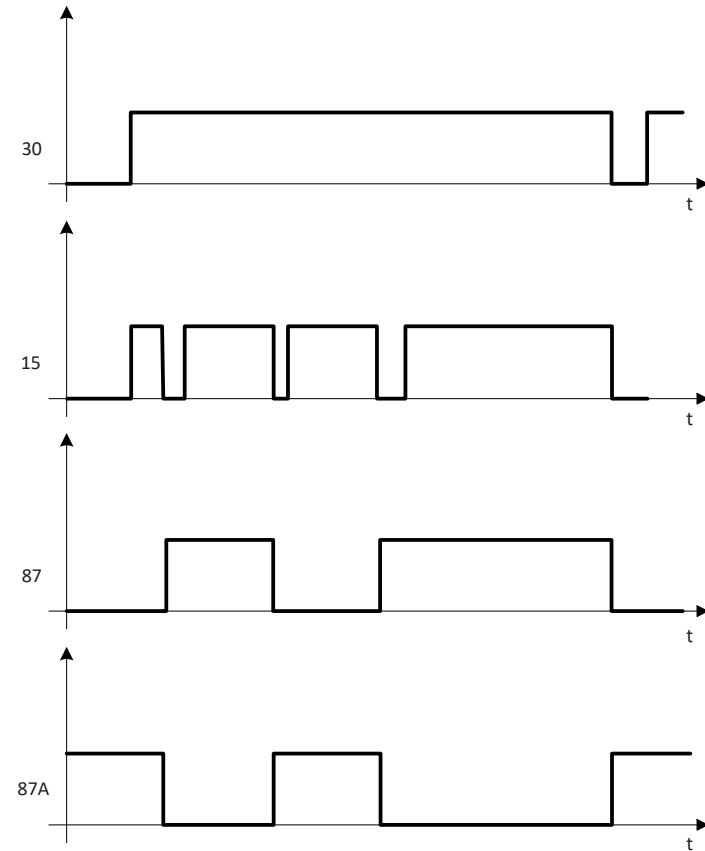



ACCESSORIES

Description	Order number
Socket package watertight 30x30x40	114265
Socket	1.017.002.00
Tab receptacle 6,3 mm/1,5-2,5 mm ²	103064



The picture might be slightly different to the original!

MANUFACTURER

MRS Electronic GmbH & Co. KG
Klaus-Gutsch-Str. 7
78628 Rottweil

NOTES ON WIRING AND CABLE ROUTING

The module must be protected with a suitable fuse against overcurrent.

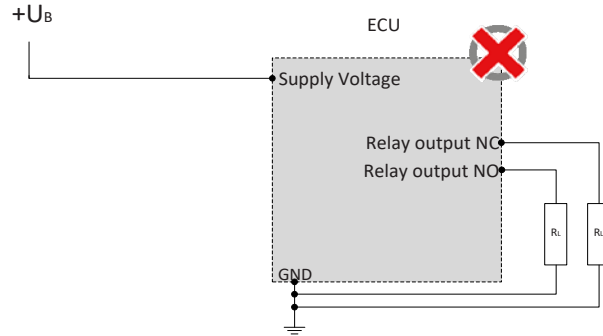
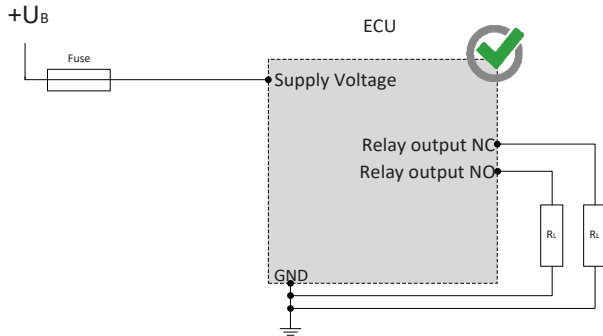

Relay outputs may only be switched to ground.

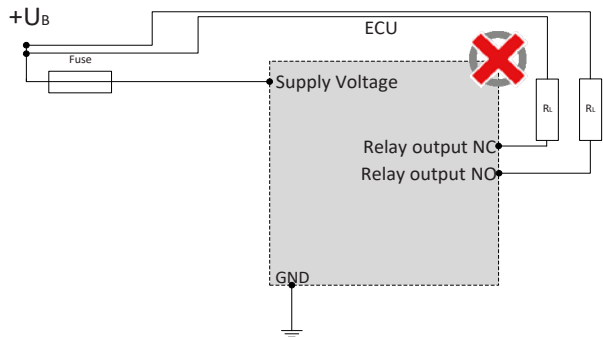
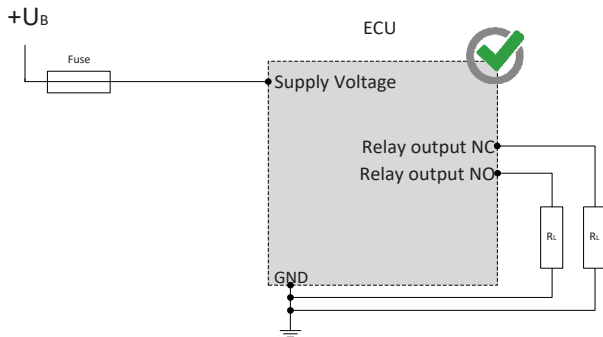

SAFETY AND INSTALLATION INFORMATION

It is essential to read the instructions in full thoroughly before working with the device.

Please note and comply with the instructions in the operating instructions and the information in the device data sheet, see www.mrs-electronic.de

Staff qualification: Only staff with the appropriate qualifications may work on this device or in its proximity.

SAFETY



WARNING! Danger as a result of a malfunction of the entire system.

Unforeseen reactions or malfunctions of the entire system may jeopardise the safety of people or the machine.

- Ensure that the device is equipped with the correct software and that the wiring and settings on the hardware are appropriate.



WARNING! Danger as a result of unprotected moving components.

Unforeseen dangers may occur from the entire system when putting the device into operation and maintaining it.

- Switch the entire system off before carrying out any work and prevent it from unintentionally switching back on.
- Before putting the device into operation, ensure that the entire system and parts of the system are safe.
- The device should never be connected or separated under load or voltage.



CAUTION! Risk of burns from the housing.

The temperature of the device housing may be elevated.

- Do not touch the housing and let all system components cool before working on the system.

PROPER USE

The device is used to control or switch one or more electrical systems or sub-systems in motor vehicles and machines and may only be used for this purpose. The device may only be used in an industrial setting.



WARNING! Danger caused by incorrect use.

The device is only intended for use in motor vehicles and machines.

- Use in safety-related system parts for personal protection is not permitted.
- Do not use the device in areas where there is a risk of explosion.

Correct use:

- operating the device within the operating areas specified and approved in the associated data sheet.
- strict compliance with these instructions and no other actions which may jeopardise the safety of individuals or the functionality of the device.

Obligations of the manufacturer of entire systems

It is necessary to ensure that only functional devices are used. If devices fail or malfunction, they must be replaced immediately.

System developments, installation and the putting into operation of electrical systems may only be carried out by trained and experienced staff who are sufficiently familiar with the handling of the components used and the entire system.

It is necessary to ensure that the wiring and programming of the device does not lead to safety-related malfunctions of the entire system in the event of a failure or a malfunction. System behaviour of this type can lead to a danger to life or high levels of material damage.

The manufacturer of the entire system is responsible for the correct connection of the entire periphery (e.g. cable cross sections, correct selection/connection of sensors/actuators).

Opening the device, making changes to the device and carrying out repairs are all prohibited. Changes or repairs made to the cabling can lead to dangerous malfunctions. Repairs may only be carried out by MRS.

Installation

The installation location must be selected so the device is exposed to as low a mechanical and thermal load as possible. The device may not be exposed to any chemical loads.

Install the device in such a manner that the plugs point downwards. This means condensation can flow off the device. Single seals on the cables/leads must be used to ensure that no water gets into the device.

Putting into operation

The device may only be put into operation by qualified staff. This may only occur when the status of the entire system corresponds to the applicable guidelines and regulations.

FAULT CORRECTION AND MAINTENANCE



NOTE The device is maintenance-free and may not be opened.

- If the device has damage to the housing, latches, seals or flat plugs, it must be taken out of operation.

Fault correction and cleaning work may only be carried out with the power turned off. Remove the device to correct faults and to clean it.

Check the integrity of the housing and all flat plugs, connections and pins for mechanical damage, damage caused by overheating, insulation damage and corrosion. In the event of faulty switching, check the software, switches and settings.

Do not clean the device with high pressure cleaners or steam jets. Do not use aggressive solvents or abrasive substances.